



Instruction and Maintenance Handbook

Trike type :

Pixel 303 XC



615 Route de l'Aérodrome, 07200 Lanas, France

Téléphone: +33 (0)4 75 93 66 66 • Fax: +33 (0)4 75 35 04 03

info@aircreation.fr • <http://www.aircreation.fr>

1 Table of Contents

1	Table of Contents.....	2
2	Amendment Record Sheet	4
2.1	Table of Amendments	4
2.2	Amendments	4
3	General.....	5
3.1	About this Document	5
3.2	Drawings	6
	<i>Figure 3-1 : Pixel 303 in 3 Perspectives</i>	<i>6</i>
4	Technical specifications – Performance	7
4.1	Performance.....	7
5	Instructions for use.....	8
5.1	Adapting Wings & Trikes	8
5.2	Assembly.....	8
5.3	Setting & Function of Controls.....	9
5.3.1	<i>Throttle</i>	<i>9</i>
5.3.2	<i>Ground steering.....</i>	<i>9</i>
5.3.3	<i>Brake</i>	<i>9</i>
5.3.4	<i>Parking Brake</i>	<i>9</i>
5.3.5	<i>Ignition Switch</i>	<i>9</i>
5.3.6	<i>Choke</i>	<i>9</i>
5.4	Ergonomics	9
5.4.1	<i>Pedals & Seat.....</i>	<i>9</i>
5.4.2	<i>Harness</i>	<i>9</i>
5.4.3	<i>Baggage Storage</i>	<i>10</i>
5.5	Preflight check.....	10
5.6	Boarding.....	11
5.6.1	<i>General.....</i>	<i>11</i>
5.6.2	<i>Pilot.....</i>	<i>11</i>
5.7	Start-up	11
5.8	Flight	12
5.8.1	<i>Prior to Take-Off.....</i>	<i>12</i>
5.8.2	<i>Take-Off.....</i>	<i>12</i>
5.8.3	<i>Cruising</i>	<i>12</i>
5.8.4	<i>Landing.....</i>	<i>13</i>
5.8.5	<i>Parking</i>	<i>13</i>

5.9	Emergency procedures	13
5.9.1	<i>Power failure on take-off</i>	13
5.9.2	<i>Power failure at altitude</i>	13
5.9.3	<i>Restart the engine in flight</i>	14
5.9.4	<i>Engine fire</i>	14
5.10	Options.....	14
5.10.1	<i>Parachute</i>	14
5.10.2	<i>Radio KRT 2 + antenna</i>	15
5.10.3	<i>Radio Icom A25 + antenna</i>	15
5.10.4	<i>Flight instrument ASV 2</i>	15
5.10.5	<i>Magnetic Compass</i>	15
5.10.6	<i>Propellers</i>	15
5.11	Specific Use / Safety Instructions.....	15
5.11.1	<i>Load Carriage, Survey Material, Data Transmission, Photo, Video &c</i>	15
6	Maintenance	16
6.1	Transport.....	16
6.2	Storage.....	16
6.3	Running in	16
6.4	Maintenance.....	16
6.4.1	<i>Trike Maintenance Schedule</i>	17
6.4.2	<i>Powerplant Maintenance Schedule</i>	18
7	Appendix.....	21
7.1	Trike – Quality Form.....	21

2 Amendment Record Sheet

2.1 Table of Amendments

Review	Date	Comment	Section
0010	09-2021	Reference document	

2.2 Amendments

The information in this manual is based on the data that was available at the time of its publication. The latest amendments to this manual will be issued on the Air Création website (<http://www.aircreation.fr>) in PDF format. This should be printed out and added to the manual. The amendment table should at that time be updated with the appropriate details and date. Therefore it is important for operators to check the website regularly for any amendments that have been made. If any errors or omissions are found in this manual please advise the factory.

3 General

3.1 About this Document

This manual is a legal document which is approved for use with Air Creation Pixel 303 trike.

It must be used in conjunction with the particular wing's operating handbook and the Polini THOR 303 Owner's Manual.

It must remain with the aircraft, and not be amended or altered without authority from Air Creation.

All pilots should read this manual before flying as pilot in command of the aircraft to which it refers.

This manual is not intended to teach you how to fly the aircraft. Learning to fly should be accomplished under the supervision of a suitably qualified flight instructor experienced in flying this type of aircraft.

What this manual will do is provide the information necessary to a qualified pilot for the safe flight of this weight-shift aircraft.

3.2 Drawings

Figure 3-1 : Pixel 303 in 3 Perspectives

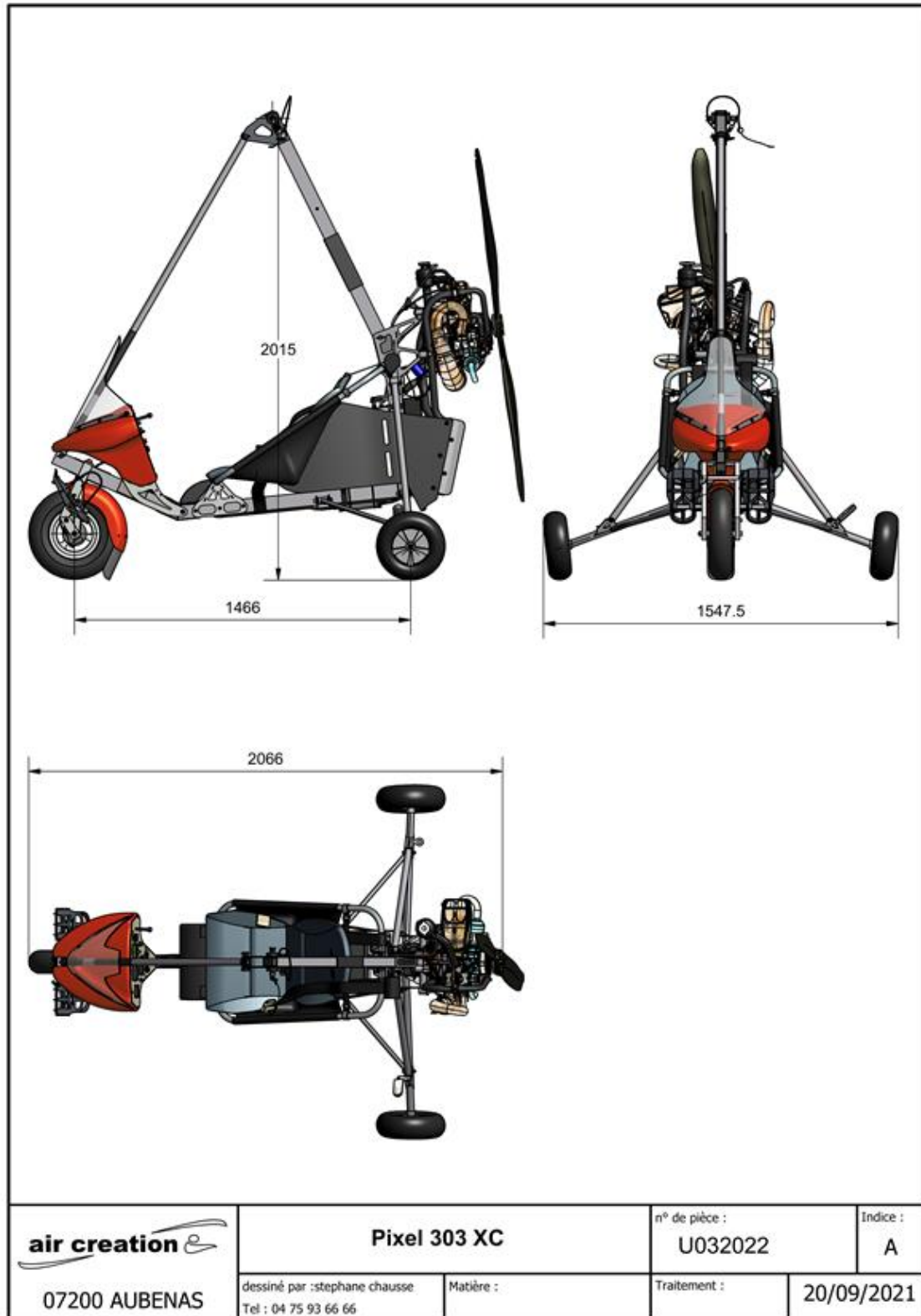

4 Technical specifications – Performance

4.1 Performance

Propeller	Helix H40F 1,5 m <i>R-GMZ-08-2</i>	E-Props 1,5 m <i>R-1300-PROP-150B</i>
Empty weight (standard)	65 kg – 143 lbs	65 kg – 143 lbs
Maximum empty weight with iFun 13 wing (SP)	140,5 kg – 310 lbs	140,5 kg – 310 lbs
Maximum take-off weight with iFun 13 wing (SP)	230 kg – 507 lbs	230 kg – 507 lbs
Maximum usefull load with iFun 13 wing (SP)	134 kg (130 kg) – 295 lbs (287 lbs)	134 kg (130 kg) – 295 lbs (287 lbs)
Maximum pilot weight	110 kg – 242 lbs	110 kg – 242 lbs
Ultimate load factors at max weight	+6g / -3g	+6g / -3g
Limit load factors	+ 4g / 0g	+ 4g / 0g
Fuel tank capacity	16 Liters 4.2 US Gal	16 Liters 4.2 US Gal
Engine	Polini THOR 303	Polini THOR 303
Maximum power	38 HP	38 HP
Maximum rpm	8 400 rpm	8 400 rpm
Reduction drive	Mechanical	Mechanical
Ratio	1:3.2	1:3.2
Maximum propeller rpm	2800 rpm	2800 rpm
Minimum height for a noise level on ground less than 65dB at maximum power	145 m – 475 ft	130 m – 426 ft

5 Instructions for use

5.1 Adapting Wings & Trikes

The Pixel trike is designed to be used with the **single-seater wing iFun 13 and SP** version of our production.

To install a wing of another brand, check all parameters (height, displacement of the control bar, propeller clearance with keel end) and make sure that there is at least 10cm clearance between the propeller and the wing structure, in all possible angles of attack and angles of bank with the hang point in its most forward position.

5.2 Assembly

1. Assemble the wing, **perform the pre-flight check as indicated in its manual**, positioning it on the nose and into the wind.
2. Wheel the trike behind the wing and line it up with the keel.
3. Raise the upper beam, push the hang point into the hang bracket, position the Ø10mm bolt and install the butterfly nut, tilt the lever back in order to tighten the plates, and secure with the safety ring.
4. Slip the back-up fastening cable into the belt loop at the king post, running it once around it. Slip it through the belt loop again and fasten it to the trike beam. The back-up fastening cable should be run under the tensioning cables. This operation secures the trike to the wing, also securing the wing cross-bar tensioning system.
5. Place the propeller to a horizontal position.
6. Raise the wing nose in a horizontal position.
7. Attach the front strut between the aluminum flanges at the top of the upper beam using the bolt and the butterfly nut.
8. Pick up the 'A' frame tubes, take hold of the control bar and lift the wing while keeping the trike from falling over or backwards. The front strut can be fitted into the opening at the front of the lower beam when the wing is lifted high enough. When alone, rotate the instrument panel (if equipped) on the seat, sit down on the trike keel facing the 'A' frame, take hold of the control bar, place it on your knees, raise the wing and fit the front strut as indicated.
9. Install the upper beam safety bolt at the engine support using the butterfly and safety ring, then install the front strut fastening bolt to the lower trike beam at the fork. Secure with the safety ring.
10. Rotate the instrument panel (if equipped) against the front tube and install the windshield by means of the 1/4-turn screws.
11. Install the foam seat upholstery using the Velcro tabs.

Dismantling is carried out in reverse order of the assembling operations.

 For folding / unfolding the iFun SP wing on the trike, refer to the wing manual.

5.3 Setting & Function of Controls

5.3.1 Throttle

The primary throttle control is a foot throttle which is connected to the right foot pedal. This is activated by pressing the foot pedal. The power of the engine increases when you push the top of the right pedal forward. In the XC version, there is also an additional hand throttle which is located on the right side of the instrument panel. Pushing the throttle lever forward increases power and pulling it back reduces power.

5.3.2 Ground steering

The nose wheel is steered by the foot pedals via cables. They work in the normal weight shift aircraft manner – i.e. push right to go left.

5.3.3 Brake

Pushing the top of the left pedal forward operates the brake on the front wheel.

5.3.4 Parking Brake

Push the brake pedal (brake action), lift the parking brake rack located behind the pedal and slowly release the brake pedal. The rack is blocked. The parking brake is spring loaded and automatically returns to the off position when the brake pedal is firmly pressed again.

5.3.5 Ignition Switch

The ignition switch is always set to ON. **Shut down is obtained by pressing on the red button on the instrument panel, if equipped, or on the tachometer block in front of the seat frame if not.**

5.3.6 Choke

The choke lever for the engine is located on the carburetor. It helps start a cold engine. The choke is activated by pulling up the lever.

5.4 Ergonomics

5.4.1 Pedals & Seat

The position of the foot pedals can be adjusted to provide the most comfortable and efficient piloting position.

The range of adjustment of the rudder pedal is up to 4,7 inches (12 cm) with 4 horizontal positions.

The rudder pedal is moved by pulling back the fork axel and setting it in the desired position.

The inclination of the seat back can be adjusted by moving the top strap of the sub-seat which can slide on the frame by loosening its two locking screws.

5.4.2 Harness

The Pixel trike is equipped with a 3-point belt that uses a conventional aeronautical buckle. Its fastening is carried out in a manner identical to that of an automobile-type belt.

5.4.3 Baggage Storage

Luggage can be stored in the following locations:

- The bag in front of the pilot, under his legs. Its maximum load is 3 Kg.
- The removable bag behind the seat. Its maximum load is 9 Kg.

The weight of the baggage shall be taken into account for the calculation of the mass of the aircraft before take-off.

5.5 Preflight check

The following is a brief summary of the minimum pre-flight inspection, which assumes that the scheduled maintenance checks outlined in the maintenance manual has been performed.

If you are unsure, it does no harm to increase the number of items in your inspection in accordance with the recommendations of the maintenance manual.

1. **Check the wing as indicated in the user's manual.**
2. Ignition switches and master switch OFF
3. Check the trike-to-wing fastenings and safety devices (bolt, nut and split ring).
4. Check that the hang point backup cable is correctly positioned and fastened.
5. Check the lower and upper fixing of front strut and safety devices (bolts, nuts and split rings).
6. Check the pylon fixation bolt and safety devices (bolts, nuts and split rings).
7. Check the engine mount assembly, rubber mounts, security and condition.
8. Check the propeller, the exhaust, its fastening springs and rubber mounts, the air filter, the carburetor and their rubber flanges for security and condition.
9. Check the fuel tank assembly, its cap, the fuel filter, the rubber pump and the fuel hoses for security, integrity, and leaks.
10. Check the coolant level in the expansion tank, the hoses and their sleeve clamps for security, integrity, and leaks.
11. Make sure the water cooler air box is unobstructed.
12. If there may be water in the fuel tank (due to condensation, fuel quality) eliminate it by disconnecting the fuel hose from the carburetor. To drain, remove the end of the tube, place it in a recipient under the tank and suction with the priming bulb. Refit the tube after draining.
13. Check of the front wheel steering assembly, position and fixing of pedals, tire condition and inflation.
14. Check the rear wheels for security and conditions, tires condition and inflation.
15. Security of seat cushions and backrests.
16. Condition of seat belt and function of buckle.
17. Check the correct closing of the storage bags in front of the seat and behind the seatback.
18. Check hand and foot throttle operation and friction. Move the throttle pedal back and forth to check that the piston on each carburetor returns to idle position. If you do not hear this particular noise, the cables may be stuck. Starting the engine under these conditions may cause loss of control of the aircraft and cause a serious accident, or even death, due to the strong push after starting.
19. Check brake pedal operation
20. Check security of windscreen
21. Check that there is no loose item in cockpit room.

5.6 Boarding

5.6.1 General

- A protective helmet must always be worn, fit correctly and secured.
- Check that you don't have any objects that can fall out of your pockets during flight.
- Ensure articles of clothing, such as gloves, scarves, glasses/sun-glasses, as well as cameras, maps, knee boards, portable navigation instruments etc. are secured. No loose objects in the cockpit !

 *Any loose object is likely to pass through the propeller arc, destroy the propeller or/and throw debris through the sail and seriously threaten the safety of the aircraft and its occupants.*

- Occupant with long hair, must have it tied up to ensure that it cannot reach moving or hot parts of the engine.

5.6.2 Pilot

Get on board from the left-hand side of the trike. The pilot should step over the lower strut while holding the front strut with the left hand. The reverse operation is recommended to exit the trike.

5.7 Start-up

 *Rotating propellers are almost invisible and can cause injury or death. Ensure that all spectators/children/pets are kept well clear of the propeller arc. On certain surfaces, stones can bounce into the propeller blades and become projectiles. Do not start an engine if any loose stones are in the vicinity of the aircraft with any spectators present at all.*

1. The aircraft has to be in a secure zone; make sure it is facing an unobstructed place while taking into account the effect of the blast of the propeller upon the surroundings.
2. Fill the tank with a mixture of premium petrol (GB) or gas(oline) (U.S.) and 100% synthetic oil in the percentage specified in the Polini engine manual (Recommended oil – Yacco MVX 1000)
3. Use the rubber pump on the fuel hose to prime the engine.
4. Use the choke located on the carburetor when the engine is cold
5. Sit in the trike.
6. Set the throttle handle (if equipped) and the foot pedal to the “idle” position.

 *You must hear the throttle valve closing before starting the engine. Move the throttle pedal back and forth to check that the piston on each carburetor returns to idle position. If you do not hear this noise, the reason may be a wrong adjustment or the cable may be stuck. In these conditions, you may lose the control of the aircraft and cause a serious accident, or even death, due to the strong push after starting.*

7. Brake the front wheel by means of the lever fitted on the pedal.

8. Check that no one is in the radius of the propeller, and activate the electric starter (if equipped) or pull the handle of the manual starter. The manual starter is equipped with a “Flash starter” system that facilitates start-up. Perform rapid pulls of the cord to “charge” the spring until start-up (cf Polini 303 manual).
9. Shut the command of the choke after a few seconds of running.

5.8 Flight

5.8.1 Prior to Take-Off

Your ultralight must be in good flight condition, that is to say maintained and used as prescribed by Air Creation.

1. Fasten the belt in the manner of an automobile belt and check for correct engagement.



Safety belts should be placed at hip level and tightened correctly. Safety belts fastened at abdominal level may cause internal injury in the event of a violent shock. The openings of the sides of the sub-seat, in which the belt passes, are arranged to naturally allow its correct positioning. Be careful not to remove them, as belt tightening at the level of the belly can cause severe internal injuries in the event of an impact.

2. Helmets secured, visor closed.
3. Clothes, personal effects & accessories attached; pockets empty or closed
4. Lower and upper fixing of front strut, blocking bolt of the rear upper strut, trike-to-wing fastenings in position and secure.
5. Level of fuel sufficient for the flight. **Never take off with a fuel level of less than 5 liters (1.3 gallons).** Check the adjustment of the rear view mirror that allows the pilot to view the fuel level in flight.



If the brake pedal has been pressed too lightly and the parking brake has not been released, the pilot may not feel its action during taxiing, but the takeoff distance will be much longer.

6. Check that the choke is off.
7. Instruments all serviceable, reading correctly.
8. Minimum parameters of engine temperature reached (cf manuel Polini 303).
9. Check that the control bar moves freely in roll and pitch axes.
10. Wind speed and direction checked, and suitable for safe take-off on selected runway.
11. Pattern and final clear, runway unobstructed
12. Release the parking brake by a short push on the brake pedal.
13. Power, check full power is achieved early in the take-off run.

5.8.2 Take-Off

Use full throttle for a short take off. Avoid *reducing or cutting the engine* below 100 m (328ft) altitude to avoid the dynamic stall that could result.

5.8.3 Cruising

Keep the aircraft level with the throttle between ¼ and full power, depending on given airspeed and load. Avoid repeated and sudden power climbs and dives to prevent sudden engine temperature changes, which could damage the engine by thermal shock.

To avoid permanent pressure on the right foot throttle, push the hand lever on the right of the control panel until it resists, then release the pedal.

To return to pedal control, press the pedal until it resists, then pull back the lever.

Checking the fuel level is done by looking in the rear view mirror located on the left side of the landing gear (right in the US). A landing should be performed when the fuel level is less than 3 l (0.8 gallons), allowing for no more than thirty minutes of flight at economic cruising speed.

5.8.4 Landing

The landing approach is best executed using the foot throttle pedal and both hands on the control bar. At maximum load, keep the throttle at $\frac{1}{4}$ of full power when on final to facilitate flare-out. Throttle back when the wheels touch the ground.

The recommended approach speed is indicated in the instruction and maintenance manual of the wing.

5.8.5 Parking

1. Park the aircraft in the crosswind and place the tip of the half-wing in the wind on the ground.
2. Turn off electronic instruments.
3. Stop the engine with the red stop switch.
4. Cut the battery power using the key.
5. Activate the parking brake.
6. Block the control bar on the front strut of the trike using Velcro® strap.
7. Leave the trike always to the left side

5.9 Emergency procedures

5.9.1 Power failure on take-off

Should the power unit fail after take-off while still at low height, maintain aircraft control and safety approach speed, and land the aircraft straight ahead without attempting to turn back to the landing field.

5.9.2 Power failure at altitude

If the engine fails for any reason, prepare for landing and carry out the emergency procedures as follows:

1. Immediately establish the best glide angle speed.
2. Check for suitable landing sites. Choose a number of preliminary options if possible.
3. Check that seat belt is tight and secure.
4. Check wind direction, either by natural indications such as smoke rising or by judging drift of aircraft over the ground.
5. Choose the most appropriate landing site.
6. Set up an approach as far as possible into wind.
7. Remember that your aircraft cannot be heard. Check that no one is on the landing site.
8. Finalize your approach, deciding upon the best landing free of any obstacles.
9. Use a short landing technique.

5.9.3 Restart the engine in flight

1. Activate the electric starter with the key (if installed) or pull the handle of the manual starter placed on the upper beam.
2. Adjust the throttle.

 *Restarting in flight may be hazardous. Keep enough altitude and stay close to a landing field.*

5.9.4 Engine fire

Should an engine fire occur during flight :

1. Maintain your flying speed.
2. Set battery switch off.
3. Carry out the emergency landing procedures as above (5.9.2).
4. Leave the aircraft and move as far away as possible.

5.10 Options

The standard empty weight used as reference to calculate the empty weight of the trike does not include the options stated hereafter. Thus it is necessary to subtract from the payload, detailed in particular wing's Pilot Operating handbook, the weight of each option installed.

5.10.1 Parachute

A pneumatic extraction parachute Comelli KOB PD45 can be installed on the trike, between the seat and the fuel tank.

The parachute will slow the descent of both aircraft and its occupant if a major problem occurs (collision, flight envelope exceeded, fainting fit etc.). ***It is advised to use it only as last solution to save life or avoid bodily harm.***

Prior to activate the parachute, it is essential to switch the engine off in order not to damage the main bridle with the rotating propeller.

The activation of the parachute is done by pulling the orange handle installed at the foot of the instrument console, between the pilot's legs.

 ***A strong pull on the handle is needed to activate the pneumatic extraction system.***

Remove the safety pin on the foot of the handle before each flight and put it back in place before leaving the trike in order to avoid unintentional extraction.

The pressure of the compressed air is 160 bar. A gauge placed on the right side of the parachute allows to control it. If the indicated pressure is outside the green range, the extraction system must be replaced.

Always inspect bridle connection points before flying. They must not be modified. When rigging the wing, bridles must be fixed with the link shackle.

The recommendations concerning inspection, maintenance periods and overall care are stated in the user's manual provided with the parachute.

The parachute does not change the flight behavior of the aircraft but its weight reduces the useful load by 4 kg (9 lbs). The maximum weight for which the parachute has been tested is 220 kg (489 lbs) at a speed of 130 km / h.

5.10.2 Radio KRT 2 + antenna

This option allows the pilot to communicate with the outside environment. Its weight of 0.6 kg (1.3 lbs) reduces the payload of the trike.

5.10.3 Radio Icom A25 + antenna

This option allows the pilot to communicate with the outside environment. Its weight of 1 kg (2.2 lbs) reduces the payload of the trike.

5.10.4 Flight instrument ASV 2

This option allows the pilot to know his air speed in flight, his altitude and his vertical speed. Its weight of 0.3 kg (0.6 lbs) reduces the payload of the trike.

5.10.5 Magnetic Compass

This instrument allows to visualize the magnetic course followed. Its weight of 0.3 kg (0.6 lbs) reduces the payload of the trike.

5.10.6 Propellers

The propeller option offers the choice of a two-blade propeller with adjustable pitch on the ground (E-Props R-1300-PROP-150B propeller weight: 1 Kg (2.2 lbs)).

The weight of this propeller is lower than the standard one (Helix H40F 1,5m (4.9 ft) R-GMZ-08-2 weight : 1,25 Kg (2.76 lbs)). The payload is thus increased by 0,25 kg (0.6 lbs).

5.11 Specific Use / Safety Instructions

5.11.1 Load Carriage, Survey Material, Data Transmission, Photo, Video &c ...

- Install the loads to be carried on the passenger seat. The holding device has to support efforts up to 9 g forward, 3 g upward and 1.5 g laterally.
- Limit the dimensions of the loads carried to avoid any contact, stress marks or blocking with the wing structure and particularly with the inferior longitudinal cables.
- Mounting any kind of camera at the tip of the wing is possible up to a maximum weight of 2 kg (4.4 lbs) if you install a counterweight at the extremity of the opposite wing. The inertia of the wing on its roll axis will increase.
- The emergency procedures stated in chapter 5.9 remain applicable.

6 Maintenance

6.1 Transport

Trikes should preferably be transported on light trailers (please consult us for further details).

6.2 Storage

The trike unit should be thoroughly checked and cleaned prior to storage. After cleaning, wipe all components with a clean lightly oiled cloth, while avoiding joints and rubberized parts.

If the trike unit is to be stored for a long period (e.g. over the winter):

- Place a well-oiled cloth in the open end of the exhaust (leaving it obvious).
- Cover the air inlet filters with several layers of protection as a precaution against condensation.
- Drain the fuel tank.

6.3 Running in

Your trike's engine had been factory tested and checked, but requires running-in. The engine should be run in on the ground as stated in the Polini instruction's manual.

6.4 Maintenance

For the maintenance of the engine, follow the instructions of your Polini manual.

 ***Never fly using a propeller unbalanced by shock or impact. Vibrations thus generated will damage the reduction gear and the trike frame. If the propeller becomes unbalanced, it should be returned to the factory for repair.***

In the event of heavy landing :

- Check the front fork, remove and inspect the fork pivot and wheel shaft.
- Check the seat frame and the lower beam for distortion. Check seat seams.
- Check the upper beam and the front tube for straightness, the swivel joint (play, hairline cracks), the engine and its rubber mounts.
- Check the rear wheel assembly and assembly clearances.

 ***If the wing has hit the ground, even slowly, have the wing disassembled and entirely checked by a technical station or our factory.***

 ***Changing all Nylstop nuts after loosening is mandatory. Always secure such nuts using LOCTITE glue.***

6.4.1 Trike Maintenance Schedule

Item	Maintenance Requirement	Hours of Operation											
		25	50	75	100 1 yr	125	150	175	200 2 yrs	225	250	275	300 3 yrs
Trike	All structural members and welds for cracks, dents, corrosion or deformation		2		3		2		3		2		3
	All fasteners for security, condition or fretting		2		3		2		3		2		3
	All rig/unfix connectors, rings and clips		2		4		2		4		2		6
	Upper beam hang point area for condition				3				3				3
	Hang bolt		2		4		2		4		2		6
	Front strut (upper and lower joints)		2		3		2		3		2		3
	Instrument console and fairings for security and cracks		2		3		2		3		2		3
	Pivot points				3				3				3
	Rear gear arms and struts				3				3				4
	Steering head for condition (distortion/cracking), free movement and play				1				1				4
	Main and nose wheels				2				2				4
	Wheel bearings for play and freedom				2				2		4		2
	Wheel Rims		2		3		2		3		2		3
	Tires pressure and wear	2	2	2	2	2	2	2	2	2	2	2	2
	Brake for correct operation		2		2		2		2		2		2
	Brake Pads and assembly		2		3		2		3		2		3
	Seat and attachments		2		3		2		3		2		3
	Safety harness for damage, deterioration and security, latches and inertia reel for faulty operation				2				2				2
	Hand and foot controls for smooth operation. Adjustment of cables.				2				2				2
	Parking brake mechanism, adjustment of cables				3				3				3
ASI Pitot and pressure instruments for leaks and proper working				2				2				2	
Parachute installation and repack (See parachute manual)				2				2				2	
Propeller	Blades for nicks and abrasion	2	2	2	2	2	2	2	2	2	2	2	2
	Mounting bolts and nuts	2	2	2	2	2	2	2	2	2	2	2	4
	Hub section for cracks, deformation	2	2	2	2	2	2	2	2	2	2	2	4
	Protective blade tape	2	2	2	2	2	2	2	2	2	2	2	2
	Blade pitch, balance and tracking				2				2				2

Code:

1. Lubricate, clean and service.
2. Check as directed.
3. Check for insecurity, cracks, wear and faulty operation.
4. Remove, inspect and replace if necessary.
5. Recommend replacement or overhaul.
6. Mandatory replacement

6.4.2 Powerplant Maintenance Schedule

The following engine maintenance schedules are of a general overview nature. The Polini engine Maintenance Manual should be used for specific maintenance required for the engine.

 *Disconnect spark plug leads prior to all maintenance and inspection.*

Item	Maintenance Requirement	Hours of Operation											
		25	50	75	100 1 yr	125	150	175	200 2 yrs	225	250	275	300 3 yrs
Engine	Loose bolts	2	2	2	2	2	2	2	2	2	2	2	2
	Cylinders				3				3				3
	Rubber mounts		2		3		2		3		2		3
	Engine Platform, Mounting plates for cracks		2		3		2		3		2		3
	Ignition Harness				3				3				3
	Battery straps and connections				3				3				3
	All wiring for condition and security				2				2				2
	Fuel sample from tank drain	2	2	2	2	2	2	2	2	2	2	2	
	Fuel lines routed properly (free from abrasion, heat and sharp edges)/fittings tight, condition	2	2	2	3	2	2	2	3	2	2	2	3
	Fuel tank and mountings, leaks, cracks and abrasion				3				3				3
	Flush out and cleaning tank												2
	Fuel filter for debris	2	2	2	2	2	2	2	2	2	2	2	2
	Throttle cable				3				3				3
	Air filter, fastening, rubber connection		2		2		2		2		2		2
	Muffler and exhaust Tubing for cracks	2	2	2	2	2	2	2	2	2	2	2	2
	Muffler springs and rubber mounts	2	2	2	2	2	2	2	2	2	2	2	2
	All switches condition and operation.				2				2				2
	Carburetors admission rubber	2	2	2	4	2	2	2	4	2	2	2	4
	Operation of all gages				2				2				2
	Tachometer operation				2				2				2
	Hour meter operation				2				2				2
	Radiator mounts		2		2		2		2		2		2
	Cooling system hoses	2	2	2	2	2	2	2	2	2	2	2	2
Expansion tank level	2	2	2	2	2	2	2	2	2	2	2	2	
Ground run at full throttle, static RPM				2				2				2	

Code:

1. Lubricate, clean and service.
2. Check as directed.
3. Check for insecurity, cracks, wear and faulty operation.
4. Remove, inspect and replace if necessary.
5. Recommend replacement or overhaul.
6. Mandatory replacement

PERIODICAL OVERHAUL BOARD

Serial number :

Date	Hours flown	Interventions	Company which has carried out the overhaul address and

PERIODICAL OVERHAUL BOARD

Sérial number :

Date	Hours flown	Interventions	Company which has carried out the overhaul address and

7.1 Trike – Quality Form

Anxious to ensure the perfection of our products, we have set up a sequence of controls covering all steps of production. We are continuously working on their improvement and we are in need of your help.

Please return this reply form accurately filled in if you find any issues or problems concerning your trike that could affect its quality or finish, even if it is a minor matter.

Name
Address
Telephone
E-Mail
Type of Wing & Trike
Delivery Date
Trike Serial Number
Engine Serial Number
Distributor
Hours Flown

Problems noticed: (explanations and/or drawing)



615 Route de l'Aérodrome, 07200 Lanas, France

Téléphone: +33 (0)4 75 93 66 66 • Fax: +33 (0)4 75 35 04 03

info@aircreation.fr • <http://www.aircreation.fr>