



## Maintenance Manual

Trike Type :

**I.s.t. SKYPPER**

**912 / 912 S**

*615 Route de l'Aérodrome, 07200 Lanas, France*

*Telephone: +33 (0)4 75 93 66 66 • Fax: +33 (0)4 75 35 04 03*

[info@aircreation.fr](mailto:info@aircreation.fr) • <http://www.aircreation.fr>

# 1 Table of Contents

---

<b>1</b>	<b>Table of Contents</b> .....	<b>2</b>
<b>2</b>	<b>Amendment Record Sheet</b> .....	<b>4</b>
2.1	Table of Amendments .....	4
2.2	Amendments .....	4
<b>3</b>	<b>Introduction</b> .....	<b>5</b>
3.1	Skills.....	5
3.2	Tools .....	5
3.3	Air Creation Directives .....	6
3.4	Units .....	6
3.4.1	<i>Use of Metric/Imperial Units</i> .....	6
3.5	Lifting & Shoring.....	7
3.5.1	<i>Lifting the Entire Trike</i> .....	7
3.5.2	<i>Lifting One Rear Wheel</i> .....	7
3.5.3	<i>Lifting the Front Wheel</i> .....	7
3.6	Transportation & Storage .....	8
3.6.1	<i>Towing</i> .....	8
3.6.2	<i>Taxiing</i> .....	8
3.6.3	<i>Ground Transportation</i> .....	8
3.6.4	<i>Long-Term Hangarage</i> .....	8
<b>4</b>	<b>Servicing</b> .....	<b>9</b>
4.1	General .....	9
4.2	Replenishing .....	9
4.2.1	<i>Fuel System Replenishment</i> .....	9
4.2.2	<i>Fuel Sampling/Draining</i> .....	9
4.2.3	<i>Engine Oil System Replenishment</i> .....	10
4.2.4	<i>Coolant Replenishment</i> .....	10
4.3	Tire Inflation .....	10
4.4	Instrumentation .....	10
<b>5</b>	<b>Maintenance Checks</b> .....	<b>11</b>
5.1	General .....	11
5.2	Time Limits.....	11
5.3	Scheduled Maintenance Checks.....	11
5.3.1	<i>Trike Maintenance Schedule</i> .....	12

5.3.2	<i>Powerplant Maintenance Schedule</i> .....	13
5.4	<b>Unscheduled Maintenance Checks</b> .....	14
5.4.1	<i>General</i> .....	14
5.4.2	<i>Inspection after Heavy Landing</i> .....	14
5.4.3	<i>Checking for Deformation</i> .....	14
5.4.4	<i>Inspection after Heavy Turbulence</i> .....	14
<b>6</b>	<b>Standard Practices – Airframe</b> .....	<b>15</b>
6.1	<b>Torque &amp; Safety</b> .....	15
6.1.1	<i>Torque Procedures</i> .....	15
6.1.2	<i>Safety Procedures</i> .....	15
6.2	<b>Inspection Notes</b> .....	16
6.2.1	<i>General Maintenance</i> .....	16
6.2.2	<i>Periodic Maintenance</i> .....	19
<b>7</b>	<b>Appendix</b> .....	<b>47</b>
7.1	<b>Maintenance Operation Board</b> .....	47

## 2 Amendment Record Sheet

---

### 2.1 Table of Amendments

Amendment date	Affected sections	Affected pages	Date inserted	Signature

### 2.2 Amendments

The information in this manual is based on the data that was available at the time of its publication. The latest amendments to this manual will be issued on the Air Création website (<http://www.aircreation.fr>) in PDF format. This should be printed out and added to the manual. The amendment table should at that time be updated with the appropriate details and date. Therefore it is important for operators to check the website regularly for any amendments that have been made. If any errors or omissions are found in this manual please advise the factory.

## 3 Introduction

---

This manual contains factory recommended procedures and instructions for ground handling, servicing and maintaining the Tanarg trike. The procedures described are to be used in addition to the particular governing body regulations for each country where the aircraft is being flown.

The operator is directed to reference the wing maintenance manual for any issues that are related to the wing component of the aircraft.


### 3.1 Skills

It is assumed that only people with an adequate skill level will perform maintenance on this aircraft. A sound understanding of mechanical systems, sufficient experience with the necessary tools and procedures and knowledge of the specific flight mechanics of weight-shift controlled aircraft is required – as the continuing airworthiness of the aircraft relies on the competence of the person performing maintenance. If there are any doubts regarding the required and appropriate maintenance, an Air Creation technical station should be contacted for the correct procedures and/or servicing.

All maintenance and repairs should be carried out in accordance with good aeronautical practices.


### 3.2 Tools

There are no specialized tools (except for the air shock absorbers) needed for the maintenance described in this manual. Following is a list of the type of tools that may be required.


 **Loctite® will be required in certain locations and should always be replaced after disassembly.**

- Loctite® 243, 270, 638 for the frame section.
- The Rotax Maintenance Manual gives a list of consumable materials in section 2.5.
- Open ended Imperial Spanner set
- Open ended Metric Spanner set
- Torque wrench (10 – 250 in.lb.)
- Air Pump (Schrader Style Valve)
- Various petroleum lubricants
- Dry Lubricant – lubricant which doesn't attract dust after application.
- Tie wire, and tooling
- Hex key set
- Various general care items

This list may not be comprehensive.

 ***Specialized pumps must be used for the air shocks – pressures up to 600 psi exist.***

## 3.3 Air Creation Directives

 *The information in this manual needs to be followed, and it is not acceptable to make changes to the materials and/or physical features of this aircraft.*

*Air Creation will, from time to time, issue airworthiness directives, which detail any changes to the maintenance manuals, Pilot's Operating Handbook, or any other details that Air Creation deems necessary for owners to be notified of.*

*The web address for Air Creation directives is:*

<http://www.aircreation.fr>

*It is the responsibility of the operator to keep up to date with any Rotax directives through the Rotax website.*

## 3.4 Units

### 3.4.1 Use of Metric/Imperial Units

This Service Manual uses the metric unit system as the basic system of measurement. Where common usage or available instrumentation refer to, the Imperial system, both units are quoted. The following conversion factors are presented as a ready reference to the conversion factors that have been used in this manual.

- 1 Pound (lb) = 0.4536 Kilogram (kg)
- 1 Pound per sq in (psi) = 6.895 Kilopascal (kPa)
- 1 Inch (in) = 25.4 Millimeters (mm)
- 1 Foot (ft) = 0.3048 Meter (m)
- 1 Statute mile = 1.609 Kilometers (km)
- 1 Nautical mile (NM) = 1.852 Kilometers (km)
- 1 Millibar (mb) = 1 Hectopascal (hPa)
- 1 Millibar (mb) = 0.1 Kilopascal (kPa)
- 1 Imperial gallon = 4.546 Liters (l)
- 1 US gallon = 3.785 Liters (l)
- 1 US quart = 0.946 Liter (l)
- 1 Cubic foot (ft<sup>3</sup>) = 28.317 Liters (l)
- 1 Degree Fahrenheit (F) = (1.8 X C) + 32
- 1 Inch Pound (in lb) = 0.113 Newton Meters (Nm)
- 1 Foot Pound (ft lb) = 1.356 Newton Meters (Nm)

## 3.5 Lifting & Shoring

The Trike may be lifted using the main attachment point for the wing or alternatively parts of the base may be lifted for local maintenance such as changing tires.

### 3.5.1 Lifting the Entire Trike

The entire Trike may be elevated from the ground using the main attachment point, the aircraft should be elevated no more than is necessary.

### 3.5.2 Lifting One Rear Wheel

Dismount the wheel fairing. While reassembling, the bolt M8x65 must be glued with Loctite® ref. 270 (strong lock wire). See Figure 3-1.

Lift the trike by the undercarriage (See Figure 3-2). Method applicable with the wing assembled).

Figure 3-1

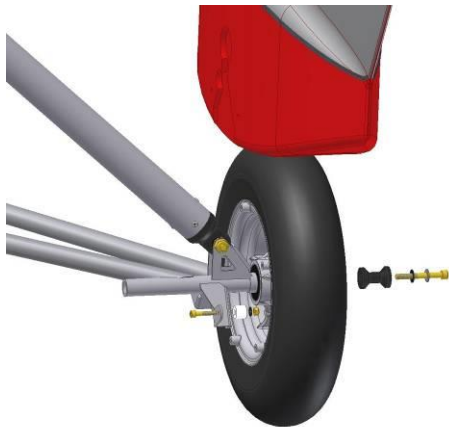
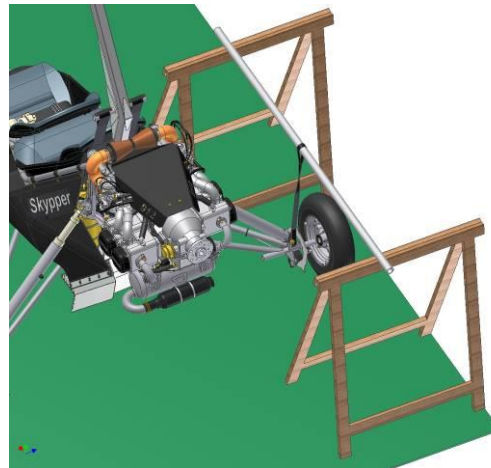


Figure 3-2



### 3.5.3 Lifting the Front Wheel

Lift the front of the trike using the passenger foot rest (See Figure 3-3). Method feasible with the wing assembled).

Figure 3-3



## **3.6 Transportation & Storage**

Moving the trike is a simple operation due to its light weight and maneuverability. One person can move it. If the front of the trike is lifted from the ground it is important to prevent the propeller from touching the ground.

### **3.6.1 Towing**

Pulling the trike with or without the wing is facilitated by lifting the front wheel. The front wheel is lifted by hand by means of the fiberglass console above the nose wheel.

The trike can also be pushed using the fairing in front of the nose wheel, and using a hand on the steering pedals inside the pod for directional control.

### **3.6.2 Taxiing**

Taxiing of the trike may be performed with or without the wing. Braking and steering are achieved by means of the front wheel. The trike should never be taxied with excessive speed.

Taxiing is a part of the training necessary for flying this aircraft. If a maintenance engineer without trike flying experience is working on the trike he should push the trike and not taxi it, as the control sense may be different to what he is accustomed to.

### **3.6.3 Ground Transportation**

The trike may be transported overland on a suitable trailer. During transport the trike base should be firmly held at both the front and the rear to prevent movement. Tie down straps should be used with a ratchet system so preload can be applied; this allows the tires to be compressed slightly so as to firmly hold the base in place during transport.

### **3.6.4 Long-Term Hangarage**

Full covers for the trike are available from Air Creation for long term Hangarage.

The Rotax manual should be consulted for long term storage.



## 4 Servicing

---

### 4.1 General

This chapter provides servicing procedures necessary to replenish or service the aircraft and its equipment as required.

The operational integrity of the aircraft systems can be seriously impaired if contaminated fuel, oil, fluids and lubricants are used or if they do not meet the required specifications. Mixture of various brands and types of materials is undesirable and should be avoided wherever possible. Specified lubricants will meet requirements for extreme hot or cold temperature operations. Use of substitutes or other lubricants may cause malfunction, or excessive wear.

### 4.2 Replenishing

#### 4.2.1 Fuel System Replenishment

##### Fuel Specification

The Skypper has a single fuel tank, capacity 55 L. Fill to the neck of the fuel entrance. Refer to the Rotax manual section 10-10 for engine fuel specifications that apply to the region where the aircraft is being flown.

**i** Due to higher lead content in AVGAS, the wear of the valve seats and deposits in the combustion chamber will increase. Therefore, use AVGAS only if the other fuel types are not available.

Special instructions and service intervals are specified when using Avgas. If Avgas is used, the Rotax web site should be referenced for maintenance requirements.

#### 4.2.2 Fuel Sampling/Draining

There is a hose and drain cock on the base of the fuel tank behind the back seat, which may be used to check the quality of the fuel, and to drain fuel if necessary. It is especially important to remove any water from the system.

##### Checking the fuel

The fuel is checked for water and contaminants by draining a sample of the fuel into a clear glass container. Once a sample has been taken the quality of the fuel can be checked by looking for any water at the bottom of the glass, and checking visually for any other contaminants.

If the fuel has been sitting for an extended period without use it may be advisable to replace it with fresh fuel.

## **Draining the Fuel**

Ensure that a suitable receptacle is found for the fuel to be drained, position the drain cock above the receptacle and depress the drain cock. Ensure that there are no ignition sources and that the fuel is disposed of correctly.

### **4.2.3 Engine Oil System Replenishment**

The minimum oil level is 2L, max 3L. Rotax has provided service instructions which detail how to check the oil.

Consult the Rotax manual for the correct type and grade of oil for the ambient operating temperature.

### **4.2.4 Coolant Replenishment**

#### **Coolant Specification**

Consult the Rotax manual for the correct type of coolant.

Rotax recommends a two year or 200-hour replacement intervals for coolant.

## **4.3 Tire Inflation**

The recommended tire inflation pressure is between 1 and 1.2 bars for both the front and rear tires. Lower pressure favors comfort and improves the ride on soft surfaces. Higher pressure reduces takeoff distance on hard surfaces. When checking the tire pressures the opportunity should be taken to examine the tires for wear, cuts, bruises, slippage and other defects.

## **4.4 Instrumentation**

There are no user serviceable parts in any of the instrumentation for this aircraft; any maintenance required should be carried out by an approved service centre.

## 5 Maintenance Checks

---

### 5.1 General

This section sets forth each mandatory replacement time, structural inspection interval, and related structural inspection procedure required.

The time limits and maintenance schedule provided are in addition to any regulation of the governing body of the country where the aircraft is flown.

The pilot of the aircraft must ensure that all required maintenance is carried out and documented in the correct manner.

### 5.2 Time Limits

Extreme operating conditions and any extreme loads will reduce the time limits for components and the fatigue life of the airframe. The fatigue life of these components is dependent upon rigid adherence to maintenance schedules. Air Creation will from time to time amend these maintenance checks as the service history of the aircraft evolves. It is the responsibility of the pilot to ensure compliance with new directives. (Information is available on the website <http://www.aircreation.fr>).

The following components are time-limited and should be overhauled or replaced as indicated. This table may be updated to include more components in the future as airworthiness directives are amended.

#### Trike Component Life

Component	Life
Hang bolt	300 Hrs
Pylon	1500 Hrs
Front tube	1500 Hrs
Trike structure	6000 Hrs
Fuel and oil hoses	5 years or replace during engine overhaul
Engine and accessories	As specified by Rotax
Propeller	As specified by manufacturer Arplast
BRS Rocket	As specified by BRS

### 5.3 Scheduled Maintenance Checks

Your ultralight should be maintained in accordance with the following schedules.


Within these schedules the following codes are used:

Code:

1. Lubricate, clean and service.
2. Check as directed.
3. Check for insecurity, cracks, wear and faulty operation.
4. Remove, inspect and replace if necessary.
5. Recommend replacement or overhaul.
6. Mandatory replacement

### 5.3.1 Trike Maintenance Schedule

Item	Maintenance Requirement	Hours of Operation											
		25	50	75	100 1 yr	125	150	175	200 2 yrs	225	250	275	300
Trike base & landing gear	All structural members and welds for cracks, dents, corrosion or deformation		2		3		2		3		2		3
	All fasteners for security, condition or fretting		2		3		2		3		2		3
	All rig/unfix connectors, rings and clips		2		4		2		4		2		6
	Hang point area for condition				3				3				3
	Hang bolt		2		4		2		4		2		6
	Front mast brace		2		3		2		3		2		3
	Instrument console for security and cracks		2		3		2		3		2		3
	Wheels spats for mud, security and cracks	3	3	3	3	3	3	3	3	3	3	3	4
	Pivot points				3				3				3
	Rear suspension swing arms and struts				3				3				4
	Rear shock absorbers				2				2				5
	Steering head for condition (distortion/cracking), free movement and play				1				1				4
	Main and nose wheels				2				2				4
	Wheel bearings for play and freedom				2				2		4		2
	Wheel Rims		2		3		2		3		2		3
	Tires pressure and wear	2	2	2	2	2	2	2	2	2	2	2	2
	Brakes for correct operation		2		2		2		2		2		2
	Brake Pads and assembly		2		3		2		3		2		3
	Seats and attachments		2		3		2		3		2		3
	Safety harness for damage, deterioration and security, latches and inertia reel for faulty operation				2				2				2
	Hand and foot controls for smooth operation. Adjustment of cables				2				2				2
Parking brake mechanism, adjustment of cables				3				3				3	
ASI Pitot and pressure instruments for leaks and proper working				2				2				2	
Parachute installation and repack (See parachute manual)				2				2				2	
Propeller	Blades for nicks and abrasion	2	2	2	2	2	2	2	2	2	2	2	
	Mounting bolts and nuts	2	2	2	2	2	2	2	2	2	2	4	
	Hub section for cracks, deformation	2	2	2	2	2	2	2	2	2	2	4	
	Protective blade tape	2	2	2	2	2	2	2	2	2	2	2	
	Blade pitch, balance and tracking				2				2				2


 *If the trike performs less than 100 hours of operation in a year, a typical 100 hour / 1 year inspection must be performed*

### 5.3.2 Powerplant Maintenance Schedule

The following engine maintenance schedules are of a general overview nature. The Rotax engine Maintenance Manual should be used for specific maintenance required for the engine.

 *Disconnect spark plug leads prior to all maintenance and inspection.*

Item	Maintenance Requirement	Hours of Operation											
		25	50	75	100 1 yr	125	150	175	200 2 yrs	225	250	275	300
Engine	Oil leaks	2	2	2	2	2	2	2	2	2	2	2	2
	Loose bolts	2	2	2	2	2	2	2	2	2	2	2	2
	Cylinders, fins				3				3				3
	Rubber mounts		2		3		2		3		2		3
	Engine Platform, Mounting plates for cracks		2		3		2		3		2		3
	Ignition Harness				3				3				3
	Battery straps and connections				3				3				3
	All wiring for condition and security				2				2				2
	Fuel sample from tank drain	2	2	2	2	2	2	2	2	2	2	2	2
	Fuel lines routed properly (free from abrasion, heat and sharp edges)/fittings tight, condition	2	2	2	3	2	2	2	3	2	2	2	3
	Fuel tank and mountings, leaks, cracks and abrasion				3				3				3
	Flush out tank												2
	Fuel filter for debris	2	2	2	2	2	2	2	2	2	2	2	2
	Throttle cables				3				3				3
	Air filters and hoses		2		2		2		2		2		2
	Muffler and exhaust Tubing for cracks	2	2	2	2	2	2	2	2	2	2	2	2
	Muffler springs and rubber mounts	2	2	2	2	2	2	2	2	2	2	2	2
	All switches condition and operation.				2				2				2
	Pylon warning lamp				2				2				2
	Carburetors admission rubber	2	2	2	4	2	2	2	4	2	2	2	4
	Operation of all gages				2				2				2
	Tachometer operation				2				2				2
	Hour meter operation				2				2				2
	Radiator mounts		2		2		2		2		2		2
	Cooling system hoses	2	2	2	2	2	2	2	2	2	2	2	2
	Expansion tank level	2	2	2	2	2	2	2	2	2	2	2	2
	Ground run at full throttle, static RPM				2				2				2

 *If the trike performs less than 100 hours of operation in a year, a typical 100 hour / 1 year inspection must be performed*

## **5.4 Unscheduled Maintenance Checks**

### **5.4.1 General**

Unscheduled maintenance is required due to abnormal loads such as severe turbulence or heavy landings. The pilot is responsible for identification of these extreme operating conditions and identification of the affected components. Where damage is found further checks should be carried out upon areas that may also be affected.

Thorough checks should also be carried out after transportation of the aircraft, and after extended storage periods.

### **5.4.2 Inspection after Heavy Landing**

Check shock absorbers for normal operation and correct length of the sliding tubes. Check all attachment points and members of the suspension system, rear landing gear and front fork. Check all welded lugs for bending or cracking of paint, which may indicate permanent deformation of the area. If any permanent deformation is identified then a more rigorous inspection of the rest of the aircraft is necessary, as permanent deformation indicates that extreme forces have been experienced by the aircraft.

### **5.4.3 Checking for Deformation**

A straight edge may be used on the tubing to ascertain straightness.

#### **Attachment Points**

Check attachment points of the wing to the base, including the main hang bolt, wheel axles and bearings. The wing should also necessarily be checked after any heavy landing because the forces are transmitted through the wing structure.

Check the main structure including the upper beam, landing gear attachment points and engine mount.

Check that all other components attached to the base are in place and properly secured.

#### **Seat Frame**

If the airframe has experienced unusual loads then the seat frames should be checked thoroughly. The weight of the pilots during impacts may damage the seat frame.

### **5.4.4 Inspection after Heavy Turbulence**

Check all components attached to the base are in place and properly secured, any other items that may have shifted due to in flight movement should also be checked on a regular basis.

Turbulence is more likely to structurally affect the wing of the aircraft rather than the trike. The Wing Maintenance manual should be consulted for instructions that pertain to the wing.

## 6 Standard Practices – Airframe

---

### 6.1 Torque & Safety

This chapter provides standard torque values and safety procedures that are to be used in all areas of the aircraft unless otherwise specified. The use of these standard values and procedures will ensure the security of installation and prevent overstressing of components.


#### 6.1.1 Torque Procedures

Correct torque of fasteners is critical, if a bolt or fastener is too loose it may cause unnecessary movement resulting in wear or fatigue, while over tightening may cause tensile failure of the bolt, or crushing of components.

##### General Torque Procedures

###### *Definition of “Just not loose”*

A definition of torque has been made for the assembly of this trike which has been called “Just not loose”, a setting which is used to achieve the best combination of strength characteristics of the tubing while not allowing any vibration or relative movement of the bolt in the axial direction. In practice this means that the nut shall be tightened adequately to ensure that each of the components that are held by it are in contact with each other, and then approximately ¼ turn more should be made. The resulting fit should not allow any axial movement of the bolt in its location, but will allow rotation (using fingers) of a held component to be achieved with approximately 20mm of lever arm.

 *In general, standard torque values will not be applicable, because of the nature of the thin wall aluminum and steel tubing that is used to construct the majority of the trike structure. Never tighten nuts so that the tubing is deformed from its circular cross sectional shape.*

*Always have at least one full thread showing past any Nylok nut that is used.*

*Where stainless steel washers are used, the rounded edge should be placed towards the aluminum tube, if any, or towards other aluminum part, if not.*

##### General Torque Exceptions

1. Joints with hinges or bearings, where free operation is necessary.
2. Bolts, nuts and screws that attach plastic or fiberglass or aluminum tube components, where the softer material would be damaged by high torques.
3. Engine bolts are to be torqued to the engine manufacturer’s specifications, and may need to be sequenced.

#### 6.1.2 Safety Procedures

- Nylstop nuts  
Nylstop nuts are used throughout the airframe. Nylstop nuts may not be reused.

- Loctite

On any bolt that does have or not a Nylstop type locking mechanism, Loctite 243 should be used to prevent premature loosening.

## 6.2 Inspection Notes

Air Creation Ultralights have been designed to permit easy inspection, and operators should have no difficulty in assessing problems or recognizing damage if visual checks are carried out correctly.

Maintenance checks may require partial disassembly of the aircraft. Inspection should include a thorough visual check of the condition of the component and the attachment point in adequate lighting conditions. Cleaning of the component may be required for proper inspection. Significant scratches, cracks, galling or any other mechanical wear of the component is reason for replacement. The Pilot's Operating Handbook outlines checks required prior to each flight.

### General care should include:

- Washing down the tube work with warm water and a mild detergent followed by rinsing with fresh water.
- Fabric sponged with warm water and a mild detergent and rinsed with fresh water.
- The fairing and wheel spats washed and polished using shampoo and polish. Treat all exposed metal components (including the engine but excluding brakes) on the trike frame (only) with a dewatering compound such as WD40. This guards against corrosion and makes cleaning much easier.

### Rust Proofing

Apart from the consequences of heavy landing, or of exceeding flight limitations, the major factors requiring attention are corrosion, fatigue and wear.

The Skypper frame is mostly made from stainless steel with the exterior protected with powder coat paint for rust proofing.

There are no known fatigue problems with Air Creation trikes, but excessive loads and vibration can weaken the structure. Regular inspection for hair-line cracks in areas under high stress, such as bolt holes, tube junctions, etc is recommended.

Some components can be replaced with ease, for difficult repairs or if the repair process is not fully understood consult your Air Creation Technical station or Air Creation factory.

### 6.2.1 General Maintenance

This section provides details necessary to carry out routine scheduled periodic maintenance on the Skypper airframe and is to be read in conjunction with the maintenance schedules (5.3.1).

#### Battery Service

A 12V sealed electrolyte battery is equipped and requires no upkeep. It is located inside the instrument console.

#### Airframe Lubrication

Most of the pivots on the trike don't require lubrication, except the front steered pivot and bearings (refer to drawing YO11100). Each of the wheels on the trike have fully sealed bearings in place that should not require user service as they have been lubricated and sealed by the manufacturer.



If no lubrication interval is specified for a component, lubricate as required and when assembled or installed.

## Cables

Control cables on the trike base include throttle cables, choke cables, steering cables and brake cables. They need to be checked regularly for excessive friction and wear. The cables have an internal low friction sleeve and must not be lubricated, because this will attract dust and create more friction. Wear is most likely to occur at the ends of the cables at the attachment points.

If wear or excessive friction is present, the cable must be replaced.


## Air Filters

Dust and dirt that make their way into the engine are probably the greatest cause of premature engine wear. The condition of the air filters should be checked each 25 hours as per the maintenance schedule, and if extreme operating conditions are experienced they should be checked more frequently. Also check the condition of the air filters after any extended hangarage.

### Air Filter Service Instructions


These service instructions apply to K&N air filters.


1. Tap the element to dislodge any large embedded dirt, and then gently brush with a soft bristle brush.
2. Spray K&N air filter cleaner liberally onto the entire element and let soak for 10 minutes.
3. Rinse off the element with low-pressure water. Tap water is OK. Always flush from the clean side to the dirty side. This removes the dirt and does not drive it into the filter.
4. Shake off all excess water and let the element dry naturally.

 *Do not use compressed air, an open flame or other heat sources. Compressed air will create holes in the element while excess heat will cause the cotton filter to shrink*

*Apply K&N air filter oil to the filter after it is dry. Apply the oil along the top and bottom of each pleat. Wait 20 minutes and re-oil any white spots still showing.*

## Cleaning

 *Do not use petroleum products or any highly flammable substances for cleaning. Do not attempt to wash an engine that is still hot or running. Allow the engine to cool fully before cleaning. Perform all cleaning operations in a well ventilated work area, preferably outside, and ensure that personal protective clothing is worn and that fire fighting safety equipment is readily available.*

 *Particular care should be given to electrical and electronic equipment before cleaning. Solvent should not be allowed to enter this equipment. Electric/electronic components should be protected before saturating the engine with solvent. Any oil, fuel, and air openings on the engine and accessories as well as the BRS parachute should be covered with a thin plastic film before washing the engine with solvent. Caustic cleaning solutions should be used cautiously and should be neutralized after use.*

### **Windshield**

The windshield is made from a polycarbonate material and therefore a certain amount of care is required to keep it clean and in good condition. The following procedure is recommended.

1. Flush with clean water to remove excess dirt, bugs and other loose particles.
2. Wash with mild detergent and warm water. Use a soft cloth or sponge, do not rub excessively.
3. Rinse thoroughly, and then dry with a clean moist chamois cloth. Do not use volatile solvents such as gasoline, alcohol, benzene or most commercial window cleaning sprays, as they will adversely affect the plastic.

### **Painted Surfaces**

The painted exterior surfaces of the aircraft can be washed using a mild detergent and water, alternatively an automotive liquid detergent may be used.

### **Engine**

An engine and accessories cleaning should be performed regularly to remove any oil, grease, and other residue. Periodic cleaning allows proper inspection of the engine components and can be an aid to discovering defects during inspection as well as reducing the potential for an engine fire during aircraft operation.

The engine may be washed down using a suitable solvent, and then dried thoroughly.

### **Propeller**

The propeller should be cleaned occasionally with water and a mild detergent to remove dirt, grass and bug stains. The opportunity should be taken to visually check the condition of the propeller during cleaning.

### **Upholstery and Interior**

The Pod area should be vacuumed out to remove all loose Dirt/Gravel etc. The seat is a structural part of the airframe and care should be taken to avoid any substance that will degrade the webbing material, vacuuming is recommended for the upholstery.

## 6.2.2 Periodic Maintenance

This section provides information necessary for periodic maintenance of the Skypper trike and should be used conjointly with the upkeep schedule.

### Fuselage structure

The fuselage structure of the Skypper is made from two main assembled components that define the main frame and from the upper beam. This does not include the landing gear.

The structure is made mainly from stainless steel.

### Main Frame

No particular maintenance is required, excepted the periodic checks for security, bending, corrosion and cracks.

### Front Tube

The front mast brace is the stabilizing member that joins the front of the trike to the top of the Mast.

The Front mast brace is mainly constructed of 2017A Aluminum. An internal safety cable provides for the unlikely event of the tube failure.

### Mast

The mast is built of stainless steel.

The trike base is attached to the wing using a bolt that attaches to the Wing U bracket.

The attachment arrangement allows the mast to move forwards/backwards and sideways relative to the hinge point. There is also the safety cable inside the upper beam to provide for the unlikely event of the main attachment failing.

For instructions regarding the attachment and maintenance of the main bolt, refer to the wing maintenance manual and the Pilot's Operating Handbook.

### Aerodynamic Fairings

The instrument console is the aerodynamic fairing on the aircraft. A cockpit fairing is optional. They are constructed from fiberglass and polyester composite material, and attached to the aircraft via bolts and brackets. The latter are attached to the main structure.

**i** When checking the spats and other fiberglass areas, ensure that they are free of cracks, crushing and delamination that may cause them to come loose.

Check the spats for mud, grass or dirt and clean the inside from debris, if necessary.

Each of the fairings should be checked regularly to ensure that the bolts are secure, and that the fiberglass to which it is attached is in good condition.

The wheel spats are attached to the frame using the brackets on the inside and outside of the rear wheels. They are held in place with bolts and washers, which are important to prevent the composite from being damaged.

The vertical stabilizer spats consist of two wheel spats with fins that protrude from the top surface, and into the airflow, providing yaw stability at high speed. The structural integrity of the spats is important for the wheel operation, and for ensuring that the outer wheel nut is secure. They should be checked every 25 hours, as noted in the maintenance schedule, as well as after any hangarage, or transport to check for impact damage that may have occurred.

#### **Fiberglass Repair**

The fiberglass components may be repaired using polyester resin and fiberglass mat, or chopped strand mat which is probably the preferable choice for easy thickness build up. Make sure that the surfaces to be repaired have been correctly prepared for adhesion. Full repair instructions for the fiberglass components are beyond the scope of this manual, there are many good texts available for practical composite repairs.

Some guidelines for repairs:

- Repair thickness should at least equal original material thickness in all cases, preferably half on the inside of the damage and half on the outside.
- For attachment points the repair thickness should be increased by fifty percent.
- Repairs should overlap damage by at least 35mm on all sides.
- Repairs are prohibited within a radius of 150mm of the Pitot tube.
- Repairs in the vicinity of the Pitot must maintain the original profile or the repair will adversely affect airworthiness.

#### **Windows**

The windshield of the Skypper is basic and should be cared for as per the instructions covered in section 4.20.10 General maintenance – Windshield.

If the windshield becomes damaged it should be replaced. Contact an Air Creation dealer.

#### **Instrument Brackets**

All of the instruments are attached to the aircraft via the instrument panel, which is attached to the Pod Fairing area. This panel is attached using screws to hold it in place.

#### **Landing gear**

The Skypper trike base landing gear assembly consists of a tricycle type undercarriage. The landing gear is non retractable.

- Front  
The front landing gear is attached to the main frame through plates and bolts assembly.  
The front suspension, steering and braking assembly is manufactured from aluminum and stainless steel. It is a “pusher” fork type assembly with welded lugs for all attached parts.
- Rear  
The rear suspension layout consists of tubular main struts for the rear suspension, welded drag link and rear strut. These are attached to the wheels and the frame via fittings. The fittings are welded and bolted to the struts and drag link.  
The rear suspension incorporates air shocks that allow pneumatic adjustment of the “spring rate” and fluid flow damping.

#### **Check**

With the weight removed from each wheel, check that each of the components is not loose. Also check each of the bearings, tire wear and the condition of the brake line.

Where excessive looseness is found the bushes and attachment points should be checked for wear and replaced if necessary. In practice this will mean that any pivot point should not have more than 0.5mm of movement, when load is applied.

#### **Damage**

Both the front and rear undercarriage allow for minor damage that does not result in dimensional changes of the materials (Permanent deformation). Tell tale signs of permanent deformation include chipped paint around highly stressed areas. Any permanent deformation warrants full checking of all possible affected parts.

### **Air Shocks**

The life of the shocks should exceed that of the aircraft due to the minimal amount of travel they will do on the ground, though they still need to be checked regularly for correct operation. If one of the shocks has lost air then they will sag to a different level relative to each other on the ground.

#### **Front Shocks**

The front shocks are protected from excessive extension by webbing. No adjustment is possible, so they must be replaced in case of weakness or wear. The webbing and stitches have to be checked too for wear.

#### **Rear Shocks**



*The rear air shocks are under very high pressure, they are preset at the factory to 30 bars and require specialized equipment to be repressurized.*

*If these shocks require service or pressure testing care should be taken to ensure that the correct equipment is available. Contact an air creation representative if such equipment is not available, the shock may need to be removed and taken to a suitable service provider for adjustment or checking.*

Check rear shock absorber air pressure. Insufficient pressure will cause the trike suspension units to sag under load or lean excessively during turns on the ground or in crosswinds.

*Every 25 landings maximum, check the length of the sliding tubes of the shock absorber set. The difference (sets at full extension) should not exceed 2 mm. If not, you should arrange for an overhaul. Moreover the overhaul of the “shock absorber” set has to be made every 400 take-off or 3 years of use.*

## Steering system

The front steering is foot activated. The foot steering system may include a linkage to the rear passenger footrest to allow passengers to steer if they are piloting (dual control option). This linkage is adjusted by modifying the position of the ball joints of the tube to allow it to adapt to the different positions of the fork and foot rest of the passenger.

## Wheels and Brakes

### Adjusting the Skypper brakes:

Unscrew the locknut located on the threaded rod of the brake pump. Screw or unscrew the rod to obtain desired setting. (Figure 6-1)

If equipped with three-brake option:

Screw or unscrew the pressure bolt located on the pressure gauge of the brake pump to obtain desired setting. (Figure 6-2)

Figure 6-1

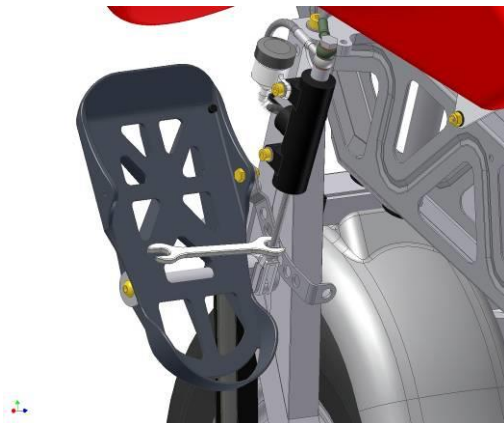
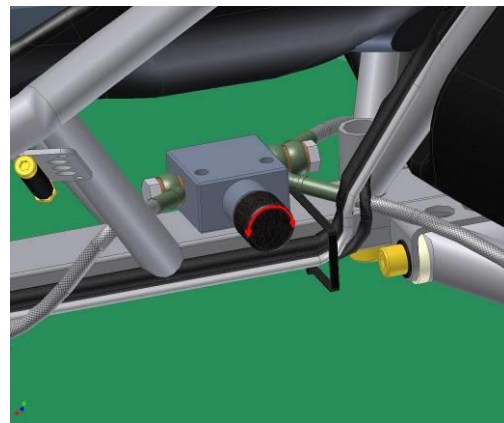


Figure 6-2



The brake pads should be inspected during the 100-hour inspections of the wheels bearings. If necessary, the pads should be replaced. As a guide brake pads should be replaced if there is less than 2mm of pad remaining. At the same time the condition of the disk, rim and other features of the Rim/Brake assembly should be thoroughly inspected for signs of damage or wear.

## Replacing the Skypper brake pads:

Dismount the wheel (see maintenance operation: changing tire).

Unscrew the 2 bolts CHC M8x40 that hold the brake clamp. Note the position of the clamp wedging washers. (Figure 6-3)

Disassemble the plastic protection and the circlip. (Figure 6-4)

Figure 6-3



Figure 6-4



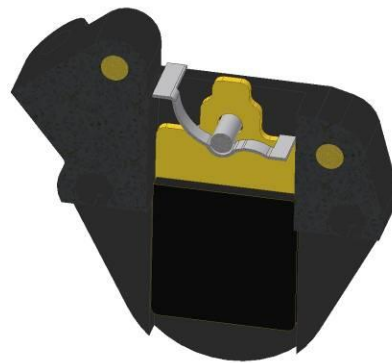
Remove the pad axis and pads as well as the leaf spring. (Figure 6-5)

Keep the leaf spring in the proper position while installing the new pads. (Figure 6-6)

Figure 6-5



Figure 6-6

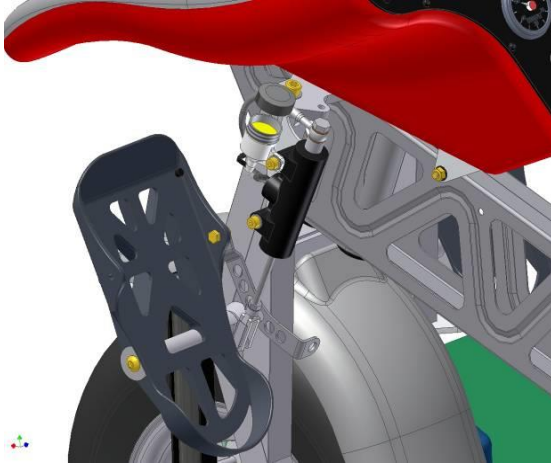


The parking brake mechanism is used to stop any unwanted movement of the trike while it is on the ground. This is activated by pressing the brake and moving the latch into the groove. The next time that the brake is pressed the latch will disengage.

## Changing the Brake Fluid

Remove the cap of the brake pump tank and fill it with type DOT4 fluid. (Figure 6-7)

**Figure 6-7**



Insert a clear tube from the drain plug to a collection recipient. (Figure 6-8)

**Figure 6-8**

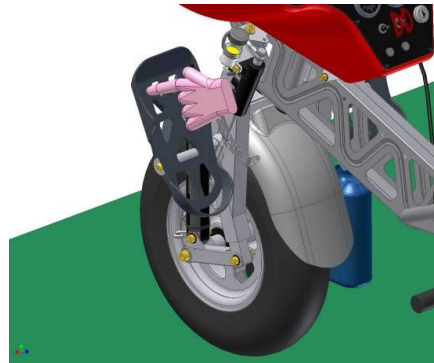


Gently unscrew the drain plug to drain the fluid. (Figure 6-9) Press the brake pedal and hold it down. (Figure 6-10) Plug the drain and release the pedal. Repeat operation until no more air bubbles escape from the drain. Refill fluid to level as you go in order not to send air into the tube. Refill completely the level once the drainage is completed.

**Figure 6-9**

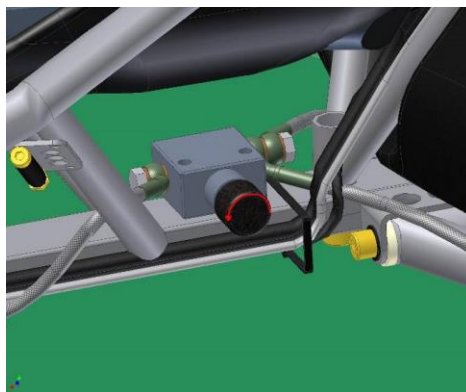


**Figure 6-10**



If three-brake option equipped: before opening the rear wheel drains, free up the passage at the pressure gauge, located under the front seat, by unscrewing the pressure screw, then open the rear drains one after the other. (Figure 6-11)

**Figure 6-11**





## Tires

**Front Tire: between 1 and 1.2 bars**

**Rear Tires: between 1 and 1.2 bars**

When operating on smooth surfaces increased pressure may be desirable, Operator experience and tire wear pattern may be used as a guide to determine modifications to the specified pressures.

When checking tire pressure, the opportunity should be taken to examine the tires for wear, cuts, bruises, slippage, and other defects and to replace as necessary.

Because the tires on the trike contact the runway in an uneven manner, the rear tires may be swapped with each other in order to utilize all of the tread. This should be done before the tire becomes worn.

Changing the Tanarg rear wheel tire:

- Lift the trike by the undercarriage (see 3.5.2 Lifting One Rear Wheel).

If three-brake option equipped:

- Unscrew the 5 bolts BHC M6 that hold the brake disc. Be careful not to brake and not to remove the brake hose (otherwise the circuit will drain).
- Remove the wheel. (Figure 6-12)

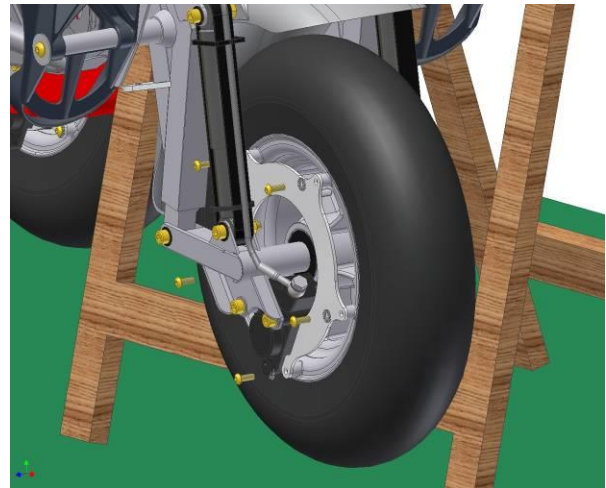
Changing the Tanarg front wheel tire:

- Lift the front of the trike (see 3.5.3 Lifting the Front Wheel).
- Unscrew the 5 bolts CHC M6 that hold the brake disc. Be careful not to brake and not to remove the brake hose (otherwise the circuit will drain).
- Unscrew the 4 bolts CHC M8x40 that hold the connecting rods to the shock absorbers and the fork.( Figure 6-13)

**Figure 6-12**

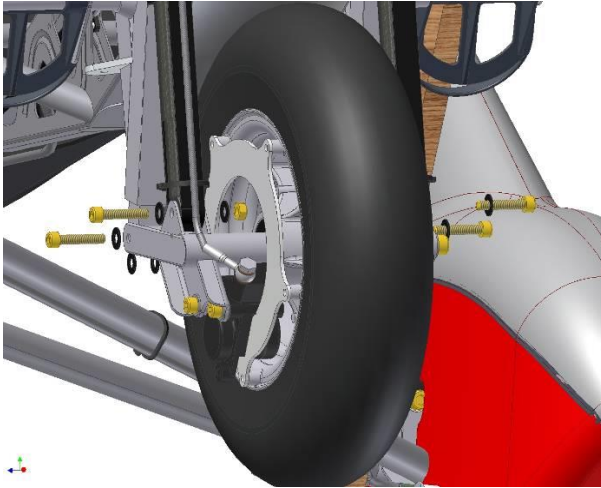


**Figure 6-13**



- Unscrew the 4 bolts CHC M8x40 that secure the rods to the shocks and fork. (Figure 6-14)
- Unscrew the 4 bolts CHC M10x50 and remove the 2 rods to remove the tire. (Figure 6-15)
- When remounting, the bolt CHC M10x50 that secures the 2 rods should be glued with Loctite® Box 270.

**Figure 6-14**



**Figure 6-15**



## Flight Compartments

The structural integrity of the webbing on this aircraft is critical for safe operation. All of the webbing should be inspected for signs of wear, fraying, cuts, or other mechanical damages, as well as any significant UV damage that may have occurred.

**i** It is preferable to store the aircraft away from direct sunlight.

### Seats

The Seats themselves structurally consist of webbing which is attached to the seat frame. The padding and other areas of the seats are non structural components

### Occupant Restraint Systems

Both the pilot and passenger seats are fitted with both lap and shoulder belts. Both of these should be periodically checked for wear and correct operation, in particular the stitching, webbing, and all attachments. Any worn or damaged belts or fittings should be replaced; this includes belts that have been subject to extreme loads during a heavy landing. It should be noted that in order to inspect the seatbelts they need to be pulled out as far as possible from their reels.

Check the shoulder harness inertia reel for corrosion, moisture and debris. Check that the belt retracts readily and locks when pulled suddenly. Check the lap belt connector for proper operation, engagement and release.

## Engine controls

### Throttle

The fuel supply system of the trike is a cable-activated twin carburetor system.

The control of the throttle and choke systems for the engine are cable-activated by the pilot. The throttle is situated on the right hand side of the dashboard, and has a double system that is activated either by hand or foot. The cables from each of the two are routed through a mixer device. The mixer also has two cables from itself to the carburetors.

Pushing fully forward opens the throttle, and pushing fully back closes the throttle. The hand throttle is only available to the front pilot, while the foot throttle may be activated by either if the dual control instruction option is fitted on the trike.

The cables and levers should be checked for free operation, and ensure that there are no kinks in the cables.

**i** If any sign of wear, damage or excessive friction is evident then the cable assembly should be replaced.

Carburetor activation is set up opposite to the standard Rotax direction, this modification is made with no changes to the parts as Rotax provides for this alternative set up. Care should be taken to replicate the changes if any carburetor replacements or overhauls are made.

### Choke

There is a separate choke control, on the right hand side, next to the rear seat.

### Adjusting the engine cables:

The adjustments of various cables can be made once the sheaths are properly set and secured. The clearance between the adjustable sheath and the sheath stop of the throttle cable or the choke cable is 1-2mm. (Figure 6-16)

The clearance of the throttle cable at the pedal level must be 2-4mm. (Figure 6-17)

Figure 6-16

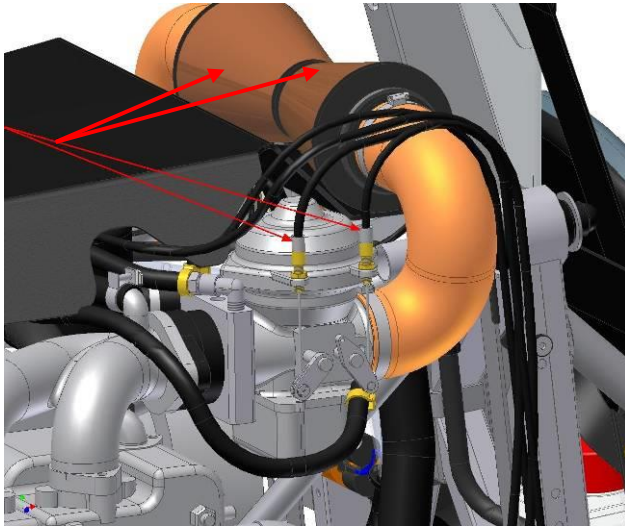


Figure 6-17



### Inspection and Maintenance

In order for the cables to operate correctly they must:

- Not be kinked or damaged
- Not be binding
- Have the sleeve properly and securely clamped at both ends
- Have the cable correctly connected to the respective engine linkage and be rotationally free so that the linkage can operate correctly through its full route without causing binding or bending/kinking of the inner.

Any problems with cable-driven controls can usually be traced to one or more of the above. Correct the problems as required. If the cable is damaged or kinked in any way it should be replaced. Care must be taken during installation not to kink the replacement cable and to ensure that the routing is correct and will not cause damage or kinking in service.

After maintenance it is necessary to carefully check the easy operation of the cables through their full range of operation, and to ensure that they are correctly secured to the appropriate linkages.

**⚠** *After throttle cables have been adjusted or replaced, the carburetor system will need to be synchronized again as per the Rotax method.*

### Electrical power

The Skypper 912 has a 12V electrical system essentially comprising of a 12V battery, the Rotax alternator and accessories. The Rotax manual should be consulted for the maintenance of the engines electrical system.

The maintenance of the electrical system should include periodic inspection of the wiring loom for chafing and other damage through its entire length. Pay special attention to the areas that are subject to possible wear points such as sharp corners or proximity to moving parts. It should be noted that the electrical wires may be subject to wear through vibration in flight.

Wiring that is damaged should be replaced. If any wear points are identified, a product such as spiral wrap should be used to cover the area. The advantage of spiral wrap is that it allows inspection of the wires even after it is attached.

## Fuses

Refer to the Illustrated Parts Catalogue. The fuses for the electrical equipment are located inside the instrument console. An 80A inline fuse protects the positive wiring and a 15A the power supply of the instrument panel.

The power supply cables for the instruments are protected by fuses. A 5A fuse is used for the 12V supply and a 5A for standard instruments. If optional instruments are fitted (radio, intercom, digital instrument etc...) complementary fuses are used to protect them. These fuses are located on a plate behind the instrument panel.

For ease of operation the control panel is designed in 2 parts. To access the fuses, the battery and all of the electrical connections, as well as the hand accelerator cable, unscrew the 11 sheet screws Ø4.2x19 on the left-hand side of the control panel. (Figure 6-18)

Remove the control panel and place it on protective foam previously rested against the front strut of the trike. The electric cables are long enough to perform this operation. (Figure 6-19)

Figure 6-18



Figure 6-19



**⚠** *Disconnect battery cables before any intervention in the electrical circuit!*

## Fuel system


Refer to the Illustrated Parts Catalogue.

The Tanarg fuel system consists of one fuel tank centrally located underneath the passenger seat of the aircraft. There is one fuel supply line equipped with a filter and a shut-off valve that runs from the fuel tank and through to the mechanical fuel pump of the engine. All of the components for the engine are standard as per the Rotax manuals, which should be consulted for maintenance information.


The Tanarg 912 Fuel system is simple and easy to inspect visually.

**Features:**

- Capacity 65 Liters.
- Fuel drain tap.
- Breather system.
- Sight gauge for remaining fuel.
- Electric Flow Meter for electronic fuel usage information.  
(Usage information provided by the digital flight display, if equipped)
- Safety fuel tap.
- Fuel filter.
- The Rotax engine contains the fuel pump. Consult the Rotax manual for instructions.

 *The flow meter and the fuel filter are directional, they must be installed so that the fuel flows in the correct direction.*

**General Precautions and Procedures**

 *Do not perform any maintenance on the fuel system in conjunction with maintenance on the electrical system. No smoking or ignition sources within 50ft or 15m from the base.*

*Fuel will degrade wing material and upholstery in the trike, care should be taken to prevent any spillage.*

**Maintenance**

**Fuel Storage**

The storage system consists of a single fuel tank located underneath of the passenger's seat. The actual fuel tank has no provision for repair, if the fuel tank is damaged in any way that makes it unsafe it should be replaced. The fuel tank must be flushed out and cleaned every 300 hours/3 years.

**Fuel Cap**

The fuel cap has a one way valve attached which allows air to enter the tank, while preventing fuel from escaping.

**Venting**

The tank is protected from positive and negative pressures by both the breather and the Fuel Cap, which allows air in if the pressure is lower or higher inside the tank than out.

**Distribution**

The fuel supply is taken from the base of the right hand side. The fuel is drawn by the Rotax fuel pump system. The Rotax manual should be consulted for maintenance and operating procedures for the fuel pump system.

There is a fuel flow rate sensor in line with the fuel supply line which supplies information to the digital instrument when fitted.

The digital display at the front of the aircraft displays the fuel consumption rate. The total usage information is also available if the counter is reset each time the fuel tank is filled.

The remaining fuel indication should be used in addition to the physical tank graduations that are visible on the fuel tank on the pilot's right. Refer to the digital instrument user manual for more information about its equipment.


### **Fuel Hoses**

The sequence of the fittings is critical for correct function of the fuel system. The fuel lines and components are secured using hose clamps.

Areas that should be checked with extra care are the interfaces between the hose and the motor. These areas are stressed to a greater degree than the rest of the tubing and are more likely to have cracks and or wear. If fuel lines need to be replaced, contact Air Creation for the correct specifications, and or replacement components.

### **Fuel Filter**

The first item after the tank is the fuel filter, correct operation and maintenance is extremely important for reliable operation of the engine. The fuel filter should be removed and checked for debris at regular intervals. If there is any damage to the filter or there is debris lodged in it then it must be replaced to avoid damage to the engine or fuel starvation. If debris are present the rest of the system should be investigated to ascertain its source.

 *The fuel filter is directional and has an arrow marked on it, which is very important. If the fuel filter has been installed incorrectly it should be replaced, to avoid debris being flushed into the engine.*

### **Oil**

The 912 engine has an external sump, and the entire system is standard to the Rotax 912 engine.

The oil specification is given in the Rotax Operators' Manual, Section 10.2.3, Lubricants. In general use only synthetic or semi synthetic oil, API classification "SF" or "SG" or higher quality oils. Multigrade is recommended. These are detergent motor oils. Consult the current Rotax manual for the correct grade of oil for the ambient operating temperature.

### **Storage**

The oil level is checked by removing the top of the oil sump, and there is a dip stick type oil level indicator. The oil level should be checked prior to each flight.

### **Distribution**

The distribution of the oil is standard to the 912 engine, the Rotax manual should be consulted for maintenance information.

The oil filter that is fitted is a Rotax RB-C308; the filter should be changed at regular intervals as per the Rotax maintenance schedules section.

### **Indicating**

The system has an oil pressure and temperature indicating system and the information is displayed on the analog instruments on the dashboard or digital if fitted.

## Draining

The sump is drained by removing the sump plug under the oil sump (912ES) or under the back luggage container (912 & 912S). Ensure that the sump plug is correctly replaced and lock-wired prior to refilling the engine with oil. Measure the amount to be replaced, refill, check the level, run the engine and recheck. The opportunity should be taken to replace the oil filter any time that the oil is replaced.

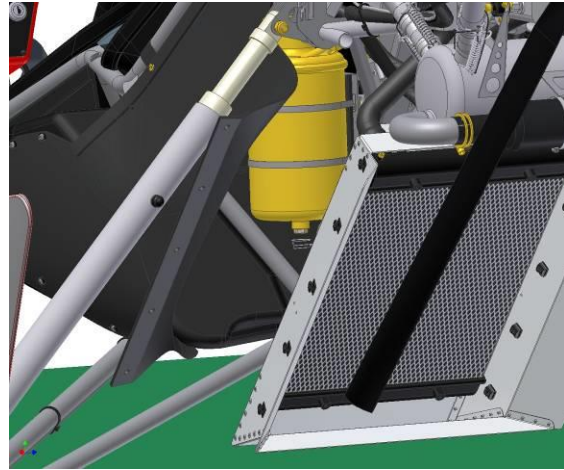
Remove the fixation strip of the left rear side.  
(Figure 6-20)

Open the left rear side and remove the security cap of the oil tank. (Figure 6-21)

**Figure 6-20**

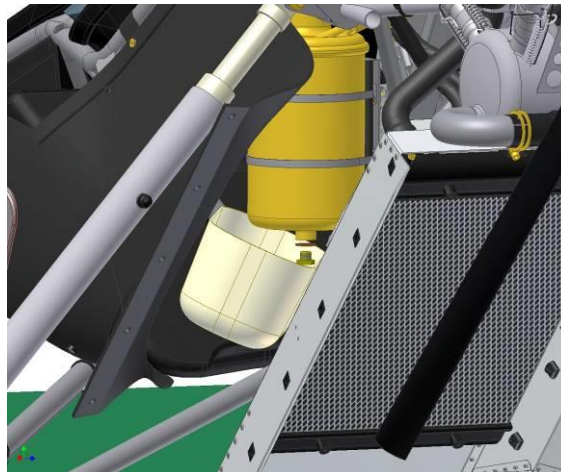


**Figure 6-21**



Place a recipient under the drain to collect the oil. Remove the plug and drain the oil. Remember to replug the drain before refilling the tank. (Figure 6-22)

**Figure 6-22**





## Coolant

The coolant specification is given in the Rotax Operators' Manual.

### Storage

The coolant level is visible thanks to the translucent bottle placed behind the passenger seat back rest. This bottle is marked with levels for minimum and maximum.

### Distribution

The Rotax manual should be consulted for maintenance information.

### Indicating

The system has a water temperature indicating system and the information is displayed on the analog instruments on the dashboard or digital if fitted.

### Coolant Replenishment

Rotax recommends two years or 200-hour replacement intervals for the coolant.

Changing the Skypper 912 coolant:

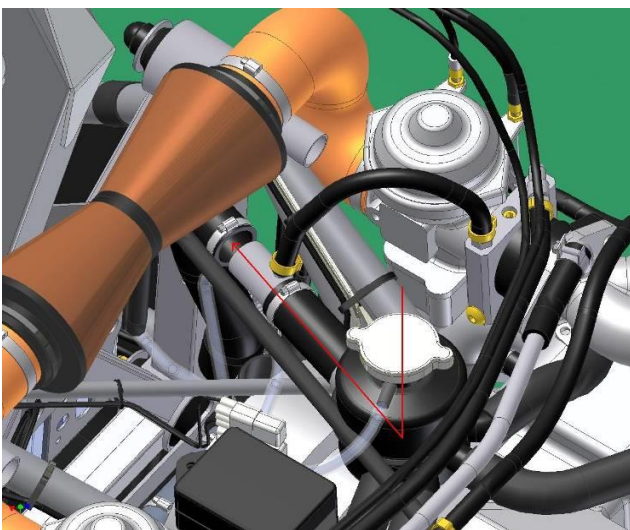
**i** It is likely that cooling liquid may flow while disconnecting. Remember to lay paper towels or protective cloth on the back fairing and on the engine.

Remove the engine cap. Remove the expansion tank cap. Insert a drainage tube into the tank and guide it toward the carburetor heater T. Siphon off the cooling liquid.

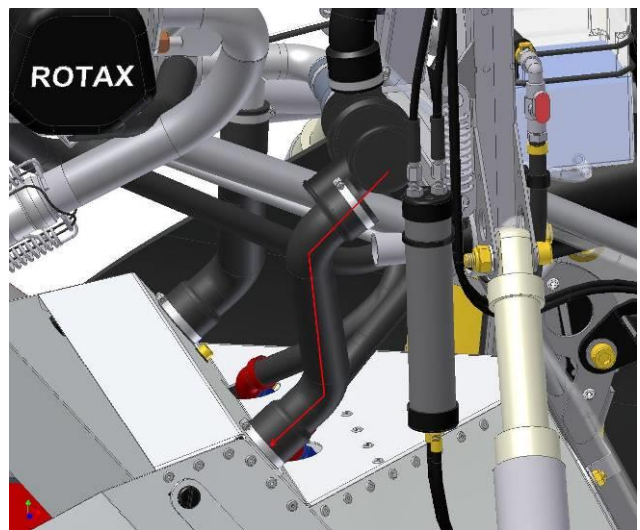
Disconnect the water hose at the outlet of the carburetor heater T and push the draining hose as far as possible toward the 3-way valve. Siphon off the cooling liquid. (Figure 6-23)

Disconnect the water hose at the outlet of the 3-way valve and push the draining hose as close as possible to the water radiator. Siphon off the liquid. (Figure 6-24)

**Figure 6-23**

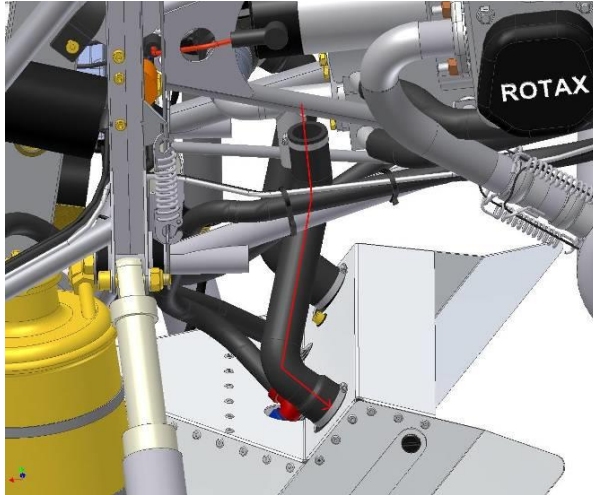


**Figure 6-24**



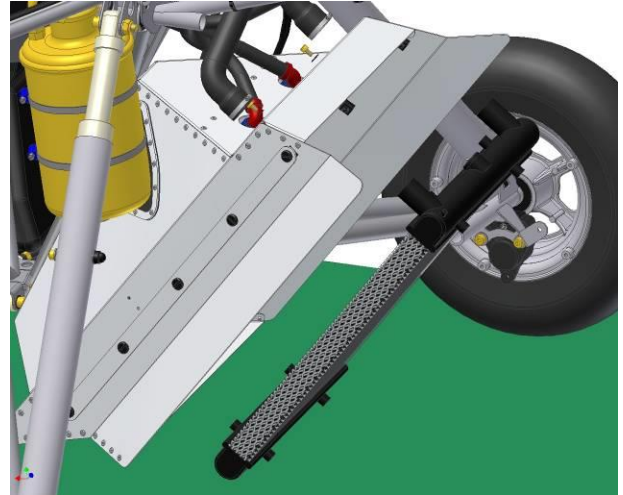
Disconnect the water hose at the steel T outlet and push the draining hose as close as possible to the water radiator. Siphon off the liquid. (Figure 6-25)

**Figure 6-25**



Disconnect the water hose at the entrance of the radiator. Unscrew the 4 bolts CHC M6x10 of the radiator and remove it. Drain the remaining cooling fluid in the radiator. (Figure 6-26)

**Figure 6-26**



## **Powerplant**

This chapter provides information on the installation of the engine, but not the engine itself, or its accessories. Information on these may be found in successive chapters.

### **Engine Run Up**

Refer to the pilots operating handbook for run up procedures. The engine should be run up to operating temperature any time that parts or fluids are replaced, or if the engine has been overhauled follow the Rotax instructions in the Rotax manual.

### **Engine Removal/Installation**

Engine removal and installation is straightforward and obvious but the following procedure may assist:

#### **Removal**

1. Disconnect the positive wire on the battery.
2. Close the emergency fuel valve.
3. Remove the propeller.
4. Disconnect all fluid flexible lines, cap and identify.
5. Disconnect from the engine, cap, and identify all electrical and instrumentation cables.
6. After the four engine mounts have been unscrewed, the engine may be carefully removed by two people, one on each side, carrying the cylinder heads. In case one person has to perform the operation, there are mounting points for a hoist on the top of the engine. The Rotax manual should be consulted for the correct bolt sizes and methods.

While the engine is off, check the condition of the engine mount, and the engine mount rubber, replace or repair as necessary.

#### **Installation**

The installation of the engine is the reverse of removal.

## Mounts

The engine mount is made of welded stainless steel. It is supported at four points through rubber shock mounts. These shock mounts should be inspected regularly for deterioration, excessive sagging and other damage. It is recommended – but not considered mandatory – to replace the shock mounts at 500-hour intervals.

Any damage or distortion to the engine mount structure should be repaired before any flight, as apart from any loss of structural integrity, distortion or misalignment of the engine mount structure could impose abnormal stress on the engine itself

## Electrical Harness

Refer to the Illustrated Parts Catalogue

The electrical harness for the system is routed on the left side of the trike, opposite the fuel lines. It incorporates the engine system, including the starter system, and the instruments wiring loom. The wiring loom is easy to find and access. It should be self-explanatory when inspected in conjunction with the Rotax manual, the trike electrical diagram and the digital instrument manual.

## Engine

This aircraft is fitted with a Rotax 912 horizontally opposed, four cylinder, and water cooled engine. This engine is proposed in two versions, 912 and 912S. Refer to the trike operating handbook for more information.

### Engine Power

Spark plugs should be the type recommended by the manufacturer. Adjusting the carburetor is a specialized job and can have a large effect on the power of the engine.

Altitude can also affect the power available. When moving to an airfield with a different elevation it may be necessary to retune the carburetor.

It is recommended that only a qualified person should tune the engine.

Other than any specific procedures specified elsewhere in this manual, detailed procedure for the maintenance and overhaul of the Rotax 912 engine fitted to the Skypper 912 aircraft can be found in the following documents:

- Rotax Operators' Manual for Rotax Engine Type 912 Series
- Rotax Documentation CD

Documentation for Rotax engine is available at <http://www.rotax-aircraft-engines.com>

The supplied manuals and documentation are supplemented by Rotax Service letters and Service Bulletins as appropriate. The Rotax website should be periodically reviewed for these updates.

Overhaul of Rotax engines should be performed by a qualified Rotax service centre.

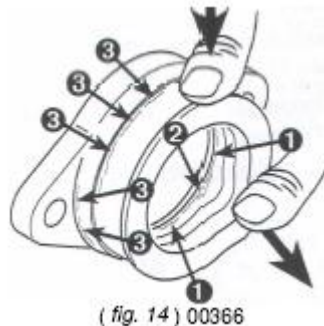
### Carburetor

When checking the carburetor rubber flanges, check for cracks. There is a Rotax service announcement (1998) which points out that there is a potential issue with the rubbers.

Compress carburetor socket in the area of the carburetor connection to allow easier detection of existing cracks (1) and (3) also check the area of the inner diameter (2). At suspicion of cracks, renew the carburetor flange.

**i** Apart from chemical strain due to fuel and UV radiation, the carburetor socket is subject to stress from vibration. Excessive tightening of the clamp may also damage it causing cracks and resulting in intake leaks.

**Figure 6-27**



### **Radiator**

If the radiator hoses are replaced, it is important that the replacement hoses are identical to those supplied with the aircraft. The engine coolant is circulated rapidly through the cooling system and the fitting of hoses other than those supplied can increase flow resistance leading to high coolant temperatures. Refer to the Rotax Maintenance Manual for detailed Radiator maintenance, and specific fluids and replacement specifications.

### **Ignition**

The power supply of the engine after starting is self-sufficient within the engine. No external power supply is required for the engine to operate. The engine generates excess power with the integrated generator, which powers the systems that are external to the engine. The Rotax maintenance manual should be consulted for the maintenance of the engines electrical system.

#### **Ignition Switch**

The ignition switch of the trike is located on the front instrument panel; this is used to start and stop the engine. If the trike is equipped with the dual control option, a second ignition switch, protected by a pivoting cover, is located on the left side of the frame, close to rear seat.

### **Exhaust**

The 912 engine is equipped with a single horizontal muffler for all four cylinders.

#### **Collector/Nozzle**

The muffler connections are all spring loaded ball joints to absorb engine vibration.

Removal and inspection of the exhaust system is simple. When reinstalling the exhaust system, Loctite® anti-seize paste should be used as recommended by Rotax. (See the Rotax manual and Loctite® instructions.)

If any minor damage occurs to the exhaust it may be repaired.

Inspect the general condition of the muffler for cracks and holes that may be present. Ensure that it is correctly secured.

## Starter

The electrically driven starter is mounted on the front left side of the engine. A key start is located on the instrument panel to activate the starter system.

The starter system is Rotax standard and the Rotax documentation should be used for the maintenance of the system.

## Engine indicators

Engine operation is monitored by the analog instruments or electronic display system mounted on the instrument panel. The engine operations monitored are:

- RPM (engine revolutions per minute)
- 2 CHT (cylinder head temperature) Celsius or Fahrenheit
- Engine Hours, in hours, minutes
- Oil temperature, oil pressure, bars or PSI
- Optional: 2 EGT (exhaust gas temperature) Celsius or Fahrenheit

The normal range for the oil temperature, exhaust temperature, cylinder head temperature and oil pressure are indicated on the instrument panel and in the electronic display, the alarm will go if any of the settings are exceeded.


## Tachometer

The tachometer system is connected to the Rotax sensor, the Rotax manual should be consulted for maintenance instructions.

## Propeller

The Skypper 912 propeller is a glass and carbon fiber composite, three-bladed Arplast propeller. It is equipped with the tool necessary to check or change the pitch.

The blades are made by pair and balanced at the factory. It is not advised to modify their weight, the adhesive label “Arplast” is part of the balancing, and the adhesive discs stuck to the rings display balancing information and must not be removed.

 *If the engine is to be rotated at any time, it should only be rotated in the same direction as it runs. Rotating the engine against the way that it runs may introduce air into the oil supply and cause damage to the engine.*

*When working on the propeller remove the spark plug leads from the spark plugs.*

## Ecoprop Propeller Assembly

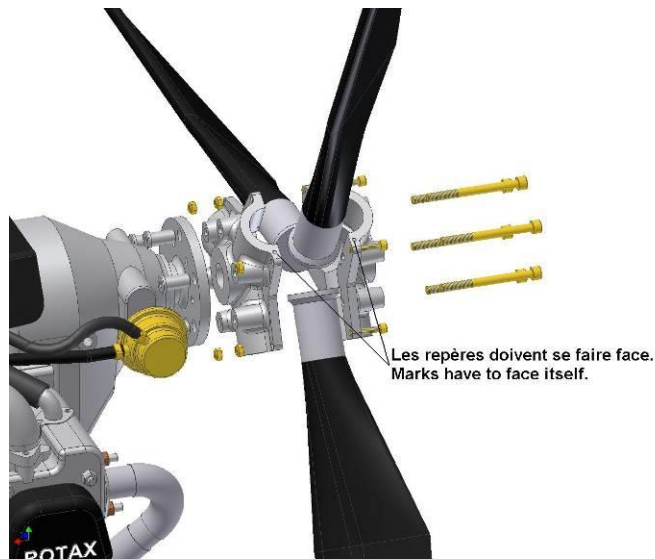
Lubricate lightly the metallic rings of the blades in order to prevent corrosion and to ease rotation while adjusting the pitch.

Place the blades into the sockets of the unmarked half of the hub opposite of the engine. Cover with the other half of the hub while respecting the position of the angular marks. Set the bolts M6 and the lock nuts of the blades, but without tightening.

Mount the 6 round-neck nuts of the propeller on the assembly flange.

Use the 6 bolts CHC M8x90 to mount the propeller on the engine flange assembly without tightening fully so that the blades can still rotate. (Figure 6-28)

Figure 6-28



Marks should face one another.

### Pitch Adjustment

Position the adjusting tool (R105848) as shown (Figure 6-29 and Figure 6-30). Adjust the pitch on all blades.

Warning: a space between the wedge and the blade area represents +/- 0.1° and may induce vibrations while operating.

Tighten moderately the bolts M8. Check the pitch on all blades then tighten the bolts M8 crosswise with a 15NM torque.

Tighten all the M6 lock nuts.

Figure 6-29

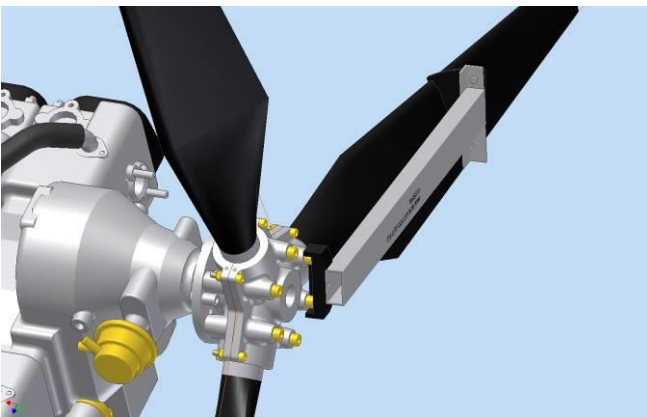


Figure 6-30



### Arplast 175/166 GWAP et 158 GWAS Propeller Assembly

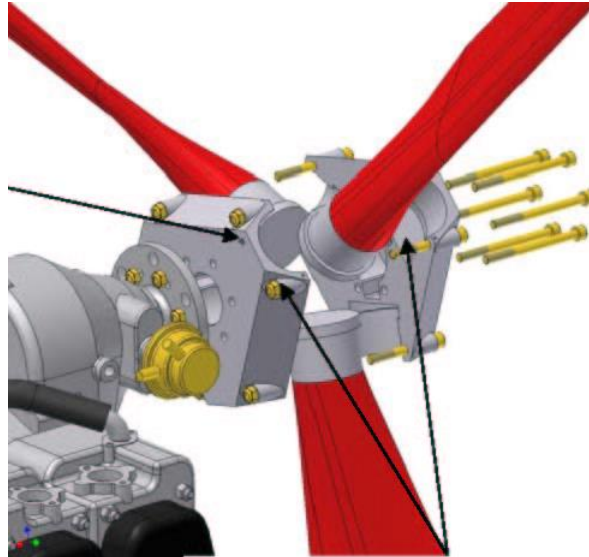
Lubricate lightly the metallic rings of the blades in order to prevent corrosion and to ease rotation while adjusting the pitch.

Place the blades into the sockets of the unmarked half of the hub opposite of the engine. Cover with the other half of the hub (marked with an F) while respecting the position of

the angular marks. Set the bolts M8 and the lock nuts M6 of the blades, but without tightening.

Mount the engine flange assembly (F on the flange) with the bolts M8x100 and the nuts without tightening fully so that the blades can still rotate. (Figure 6-31)

**Figure 6-31**



**Marks should face one another.**

### **Pitch Adjustment**

Position the adjusting tool 62G as shown (Figure 6-32 and Figure 6-33). Adjust the pitch on all blades.

Warning: a space between the wedge and the blade area represents  $\pm 0.1^\circ$  and may induce vibrations while operating.

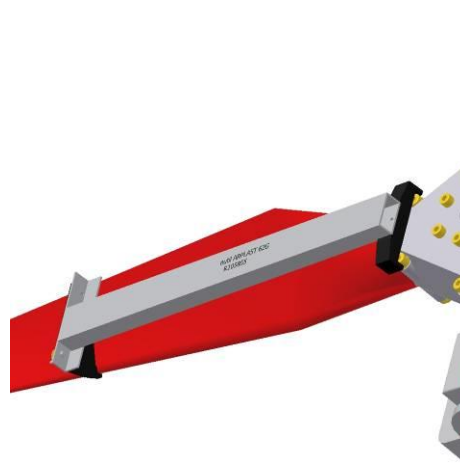
Tighten moderately the bolts M8. Check the pitch on all blades then tighten the bolts M8 crosswise with a 15NM torque.

Tighten all the M6 lock nuts.

**Figure 6-32**



**Figure 6-33**



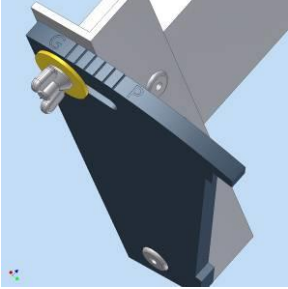
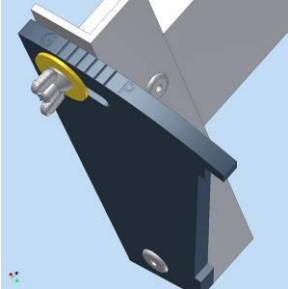
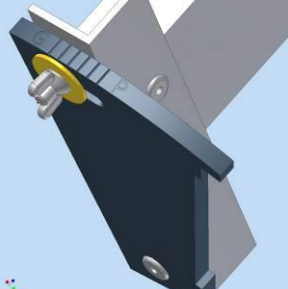
### Choice of Pitch

On ground and without other information, the setting to obtain before a flight test should be +/-80% of maximum setting.

In use, the engine should turn at the maximum RPMs authorized by the constructor at the highest possible level flight speed. The final setting should be corrected in favor of “cruising” or “climbing” for a slightly higher or lower blade angle.

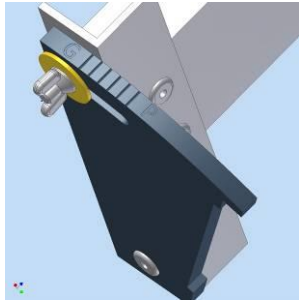
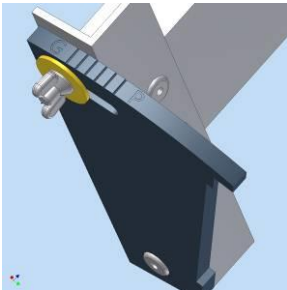
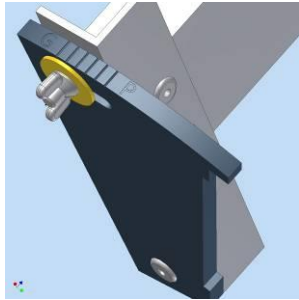
### Factory Standard Settings

#### Rotax 912 UL

<p>Propeller: Arplast 166GWAP62 Tool : 62G Setting : 3rd notch from the G (Figure 6-34)</p>	<p><b>Figure 6-34</b></p> 
<p>Propeller : Ecoprop eco gl3 Tool : eco GL/3 Setting : 4th notch from the G (Figure 6-35)</p>	<p><b>Figure 6-35</b></p> 
<p>Propeller: Arplast 158GWAS62 Tool: 62G Calage : between the 2<sup>nd</sup> and 3<sup>rd</sup> notch from the G (Figure 6-36)</p>	<p><b>Figure 6-36</b></p> 



## Rotax 912 ULS

<p>Propeller : Arplast 166GWAP62 Tool : 62G Setting : 2nd notch from the G (Figure 6-37)</p>	<p><b>Figure 6-37</b></p> 
<p>Propeller : Ecoprop eco gl3 Tool : eco GL/3 Setting : 3rd notch from the G (Figure 6-38)</p>	<p><b>Figure 6-38</b></p> 
<p>Propeller : Arplast 158GWAS62 Tool : 62G Setting : between 4th and 5th notch from the G (Figure 6-39)</p>	<p><b>Figure 6-39</b></p> 

### Inspection

With the propeller removed from the aircraft and each of the components separated, the blades and boss should be inspected for the sort of damage described below paying particular attention to those areas that are not visible when the propeller is installed. In addition, the following checks should be made:

- Bolt holes should be examined for unrounded, rough edges, and cracks radiating into the hub.
- Check the whole surface of the hub especially in all corner areas. Make sure surfaces are clean and lighting is good. Use a magnifying glass for close inspection.
- The center bore of each blade should be examined for cracks and delamination of the layers.
- Take note of any sharp nicks, cuts or scratches, as these are stress points from which further problems may occur. Take action if required.
- Inspect the propeller and hub in the area around where the prop exits the hub.
- Inspect the bolts, replace if any wear or damage is present.
- The mounting hub should be examined for corrosion, cracks, and correct fit on the gear box.

## **Blade Damage and Repair**

The condition of a composite propeller is important for safe flight. The pilot of the aircraft needs to check the condition of the propeller prior to each flight and ascertain its airworthiness. In general deep scratches across the chord of the propeller are most significant, along with leading edge dents and damage that may lead to delamination.

Leading edge damage is repairable as long as it is not larger than the sizes specified below and that the propeller is not delaminated. In general if the specified damage size on the surface of the propeller is not exceeded, then it is better to leave the surface alone, as filling minor scratches will likely cause more damage. If any doubts exist as to the condition or repair procedure for the propeller either return the propeller to Air Creation, manufacturer Arplast-helice or consult an engineer, or equivalent technician, who has experience with composite materials.

### **Balancing**

Balancing the propeller should not be necessary if the damage allowances are observed; repairs should only replace exactly what has been removed.

If there is any doubt or if propeller balancing is necessary, the propeller must be returned to Air Creation or manufacturer Arplast-helice.

### **Leading Edge Tape**

The propeller blade types 158 GWAS and Ecoprop GL3 are supplied with a light grade of Urethane Protective Tape applied. This will help the propeller resist the abrasive effects of dust, sand & water etc. It will not stop solid objects from damaging the blade, although it will help reduce the damage. If the tape is damaged, it has done its job and should be replaced except if the blade is damaged under the tape. In this case, the tape must stay in place until the reparation has been done, in order to protect the dent from engine exhaust fumes.

### **Damage Allowances**

All propellers will eventually suffer damage from a variety of causes and in differing degrees.

Varieties of damage such as water, stones, gravel & sand makes it very difficult to specify maximum damage levels before the blade should be replaced rather than repaired.

The propeller's design and material (unlike wood, metal) is to progressively increase strength from tip to root. As such a solid tip strike is not likely to destroy the hub or root of the blade, (leading to a catastrophic failure) Damage is far more likely at the tip (as tip speed is much higher) but less critical as it has less force acting upon it (compared to the root/hub). As all force is focused on the root and hub sections – these areas are not likely to be damaged. If any doubt exists as to the airworthiness of a propeller, have it properly assessed prior to flight.

### **Surface Scratches**

The inner 250mm of the prop should not be damaged any further than minor nicks and paint scratches and the sleeve between the root and the aluminium foot. This is because it is exposed to the most force. This area is harder to damage than further out on the radius because the speeds are lower but they could be signs of delamination, cracks or surface deformations. These signs means that a internal structural break exist. The complete break of the blade is not far. The propeller must not be used anymore before examination

by Air Creation, the manufacturer Arplast-helice or an engineer, or equivalent technician, who has experience with composite materials. Except this extreme case, as a guide, there should be no more than three scratches of 0.1mm deep, and 25% of the chord in this area of the blade.

From a radius of 250mm from the hub to the tip of the propeller the depth allowance is slightly greater at 0.15mm and extending a maximum of 25% of the chord but the fibers of the material must not be seen. Slightly more damage is allowed toward the tip. There should not be a concentration of scratches in one area, even if they don't affect safety, they must be repaired as soon as possible.

### **Leading Edge Damage**

The Arplast 175/166 GWAP propellers have their leading edge made with a soft polyurethane material that can be repaired in the same way than the 158 GWAS but the epoxy glue used for repair will not have the chock absorption qualities of the polyurethane.

For the 158 GWAS and Ecoprop GL3 propellers, maximum allowed leading edge dent is 3mm within 250mm of the root, and 8mm at the tip. The depth of the dents allowable varies linearly from 250mm to the tip of the blades.

The number of dents allowed depends upon their size. It is suggested that two or three per propeller blade is the maximum.

### **Repair**

To repair all dents and scratches a slow cure EPOXY resin must be used. Larger cavities must be filled with slurry made of a suitable Epoxy plus finely milled glass fibers or talcum powder in two stages: Freshly mixed Epoxy should be wet then wait until it thickens to fill the hole. For cosmetic scratches and dents use talc with the epoxy. Always follow the resin instructions and apply to a clean dry surface. The temperature should be at least 20°C (68°F) and the relative humidity as low as possible. Do not use a cleaning solvent unless there are oil or grease stains around the hole. Use a flat block and sand paper to slightly smooth out the edges of the hole (leading edge) if these stick out, then scrape with a pointed tool to remove composite debris from the cavity. Avoid overflow or spilling Epoxy outside of the hole, adjust the quantity with precision so that the hole is exactly filled. Place a new adhesive strip (new advertising adhesive, PVC film on silicon paper, or thick packing adhesive strip, transparent if possible) on the upper surface so as to form a cup around the hole, which will act as a mold in order to reduce sanding. When the dent is filled, sand carefully in order to return to the original airfoil. Every fiber cut in sanding is a fiber that is lost for structural resistance! The Epoxy hardens completely in a few days at room temperature but can still be molded for a couple of hours after mixing. During this time, it is possible to remove drips and spills with a cloth and solvent (acetone, chlorinated solvent or simply methylated spirits). Once the airfoil is returned to its original state, apply a new protective film to the blade (158 GWAS or Ecoprop DL3).

**i** If in doubt, or if the propeller has more damage than can be fixed by the operator then return the propeller to Arplast factory.

## Ground Run

After adjustments or maintenance and prior to flight the engine should be run up to check that the propeller is functioning normally. The tracking of the propeller should be checked.

The aircraft should be securely chocked and the engine runs up to full speed. Ensure that the engine is at the required operation temperature. Check that the propeller is functioning normally with minimum vibration.

## Navigation and Pitot Static

This chapter provides information on those systems that provide the aircraft navigational data such as the Pitot static system, Airspeed indicator, and altimeter.

### Flight Environment Data/Pitot Static

The Pitot system is located at the front, on the left side of the instrument console. From the splitter PVC ID tube continues to the analog air speed indicator or digital panel if fitted. The tube may be replaced if necessary. Check that the Pitot port is free of obstruction, or insect nests. The lines may be visually checked from the inside of the pod for obstructions as the tubing is transparent.

Leaks, moisture and obstructions are the major problems associated with Pitot Static systems.

Provided these problems are adequately addressed, the Pitot Static system is essentially maintenance free.

If it becomes necessary to blow through either the Pitot or the static system in order to clear blockages etc. the system should be disconnected at the instrument end and blown out with clean, dry air from that end.

Avoid blowing through by mouth as this will introduce moisture. Never blow air through from the source end, particularly with the instruments connected, or they will be ruined.

### Testing the Pitot System

The Pitot system is to be tested for leaks by applying pressure on the Pitot head sufficient to cause the airspeed indicator to read 90 knots. There should be no indication of restrictions in the application of the pressure and no decrease in the reading when the system is sealed for at least 10 seconds.

### Testing the Static System



*The Pitot is a very sensitive instrument, and is easily damaged; read the instructions carefully before continuing with the test procedure. Understand that the amount of pressure needed to test the Pitot is low.*

*Never use compressed air, or blow into a Pitot system.*

Testing the Pitot can be achieved by carefully using a syringe and flexible tube, sealing it to the front of the Pitot entrance and introducing a very small amount of pressure. The amount of pressure is very minimal. At 46.3m/s (90kts) the pressure necessary is only 134mm water or 1.34kPa (0.194PSI). In a 50cc syringe this will equate to somewhere in the region of 2-5mm of distance. If the flexible tube is long enough the testing can be

done from the cockpit while looking at the instruments; alternatively a helper will be required.

**Other Instruments:**

Other instruments that need to be tested (such as the air speed indicator and the altimeter) should be calibrated on an independent instrument, or sent to a service agent for checking and calibration.

**Avionics**

All maintenance and servicing of avionics communications equipment fitted to the Skypper 912 should be carried out by approved agents of the avionics manufacturer.

**Special purpose equipment**

**Parachute System**

If a parachute is fitted to this aircraft, a parachute manual will be supplied as a part of the data package.

The manual must be read by the owner, and the manufacturer's instructions followed for the maintenance and use of the parachute. The maintenance of the Parachute system should be recorded in the aircrafts log book.

The system has one or two handles. The front one is located just in front on the center of the seat frame. The second one, if fitted, is located on the right of the rear seat.

The front handle is coupled with a kill switch in order to stop the engine when pulling the handle.

**Maintenance**

The maintenance of the system is limited to ensuring that the attachment point is secure, and that the bridles to the BRS rocket and parachute are free of abrasion, and kinking. Also check for any damage of the handles and associated kill switch.

The maintenance schedule for the BRS parachute is given in the manual that is supplied with the system, and should be followed to ensure reliable operation of the parachute.



# 7 Appendix

---

## 7.1 Maintenance Operation Board

Trike Type: \_\_\_\_\_ Serial Number: \_\_\_\_\_

Date	Hours Flown	Type of Operation Performed	Operator Name, Address, Stamp

Date	Hours Flown	Type of Operation Performed	Operator Name, Address, Stamp



Date	Hours Flown	Type of Operation Performed	Operator Name, Address, Stamp



*615 Route de l'Aérodrome, 07200 Lanas, France*

*Téléphone: +33 (0)4 75 93 66 66 • Fax: +33 (0)4 75 35 04 03*

[info@aircreation.fr](mailto:info@aircreation.fr) • <http://www.aircreation.fr>